Quick Installation Guide

7.3kW&11kW AC EV Charger

L07P

L11P



Contents

1	Notes on This Manual	1
1.1	Scope of Validity	1
1.2	Target Group & Symbols	1
1.3	Explanation of General Symbols	1
2	Safety and Technical Information	2
2.1	Technical Specifications	2
2.2	Safety	3
3	Preparation	4
3.1	Packing List	4
3.2	Tools Required (Not Supplied)	5
4	Product Introduction	6
4.1	Product Overview	6
4.2	Earthing System Requirements	6
5	Installation	7
5.1	Wall-Mounted Installation	7
5.2	Preparing Cable Entry (Bottom or Rear)	8
5.3	Power Supply Connection	9
5.4	Network connection (Optional)	10
5.5	RS485 Connection (Optional)	10
5.6	Completing the Installation	11
5.7	Meter or Inverter Connection (Optional)	12
6	FoxSwitch App Setup (Installer)	13
6.1	Device Binding	13
6.2	Network Configuration	14
7	Charging Modes and LED Indicators	15
7.1	Charging Modes	15
7.2	LED Indicator Reference	15

1 Notes on This Manual

1.1 Scope of Validity

This manual describes the installation and commissioning of the following product models:

L07P / L11P

Please keep this manual accessible at all times.







1.2 Target Group & Symbols

This manual is intended for use by qualified electricians only.

Symbol	Meaning
Warning	“ Warning ” indicates a hazardous situation which, if not avoided, could result in death or serious injury.
Note	“ Note ” provides important tips and guidance.

1.3 Explanation of General Symbols

The following symbols appear on the product label and enclosure:

Symbol	Meaning
	Complies with applicable European Union directives.
	Enclosure may become hot during operation. Avoid contact.
	Danger of electric shock. Do not open cover while energized.
	Complies with applicable United Kingdom regulations.
	Please read the user manual carefully.
	Do not dispose of with household waste. Dispose of at a designated e-waste collection point.
	Complies with applicable Australian and New Zealand regulations.

2 Safety and Technical Information

2.1 Technical Specifications

Rated Values

Parameter	7.3 kW Model	11 kW Model
Rated supply voltage	230 V AC (1-phase)	400 V AC (3-phase)
Rated current	32 A	16 A
Rated frequency	50/60 Hz	50/60 Hz
Rated output power	7.3 kW	11 kW
Protection degree	IP55	IP55
Operating temperature	-25 °C to +50 °C	-25 °C to +50 °C
Altitude	≤ 2000m	≤ 2000m

EVSE Classification

Classification Category	Description
Power supply input	AC supply network
Power supply output	AC output
Connection type	Permanently connected
Environmental conditions	Indoor and outdoor
Access	Restricted access (installation) / Non-restricted access (operation)
Mounting method	Wall-mounted or post / pillar-mounted (optional)
Ventilation	Not supported / Not applicable for AC charging (Mode 3)
Protection against electric shock	Class I
Charging mode	Mode 3

2 Safety and Technical Information

2.2 Safety

EV chargers are designed and tested in compliance with **EN IEC 61851-1**.

Installation and maintenance shall be performed **only by a certified electrician** in accordance with local wiring regulations.

Before installation, inspect the unit for transport damage. Do not install a damaged unit.

Unauthorized removal of protective devices, improper use, incorrect installation, or improper operation may result in serious safety hazards, electric shock, or equipment damage.

Do not install in adverse environments: near flammables or explosives, in corrosive or desert environments, or in areas with extreme temperatures or high humidity.

Do not operate the charger if any safety device is inoperative or has been disabled.

Always wear appropriate **Personal Protective Equipment (PPE)**, including **electrically insulated gloves** and **safety goggles**.

All repair work must utilize only approved spare parts and be performed by a licensed contractor or authorized service provider.

RCD Requirement: This charger integrates a **6 mA DC leakage detection device (RDC-DD)** compliant with **IEC 62955**. The external supply circuit must be protected by a **Type A RCD** ($I\Delta n \leq 30 \text{ mA}$) or a **Type B RCD**. **Type AC RCDs are prohibited.**

Earthing: This product includes protection against PEN conductor faults for **TN-C-S (PME)** systems. For **TT systems**, a local earth electrode must be installed in accordance with local regulations. Refer to Section 4.2 for details.

3 Preparation

3.1 Packing List

Verify all items are present before installation.

A. Wall Mounting Kit

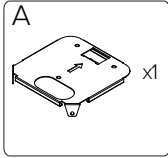

Mounting backplate

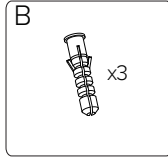

Wall plug
($\varnothing 8 \times 40 \text{mm}$)

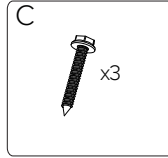

Lag screw
(ST6*40mm)

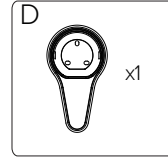

Type 2 Plug holder

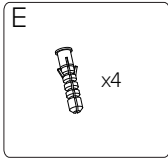

Wall plug
($\varnothing 6 \times 30 \text{mm}$)

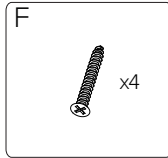

Lag screw
(ST4.2*35mm)

B. Electrical Connection Accessories

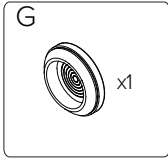

Rubber grommet
(M40)

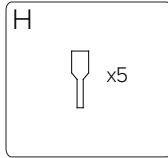

Ferrule terminal
(for L/N/PE)
(E6012)

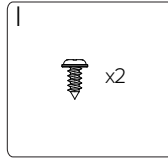

Self-tapping screw
(for bottom cover)
(ST4.2*9.5mm)

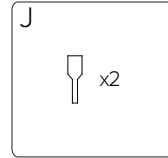

Ferrule terminal
(for RS485)
(E0508)

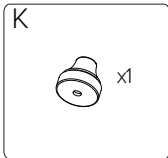

Rubber grommet
(M16)

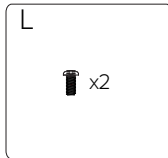

Torx pan head screw
(for top cover)
(M3*6mm)

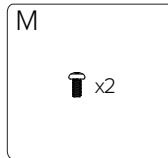

Pan head screw
(for cover)
(M3*6mm)

C. Documentation & Accessories

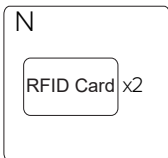

RFID Card

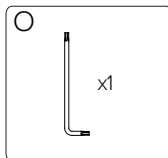

Wrench (T10)

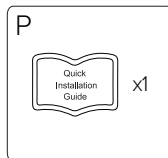

Quick installation
guide

3 Preparation

3.2 Tools Required (Not Supplied)

The following tools are required for installation. They are not included in the packaging:



Electric drill



Masonry drill bits: \varnothing 8mm



Masonry drill bits: \varnothing 6mm



Spirit level



Markers

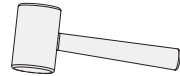

Hammer



Step drill bit
(for rear entry knockout)

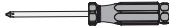

Cross-head screwdriver

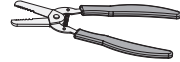

Wire stripper

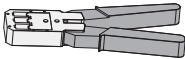

RJ45 crimping tool
(if Ethernet connection
is used)



Multimeter (for supply
isolation verification)



Crimping pliers
(for E6012 and
E0508 ferrules)



Insulated gloves (PPE)



Safety goggles

4 Product Introduction

4.1 Product Overview

Refer to the illustration below for component identification.

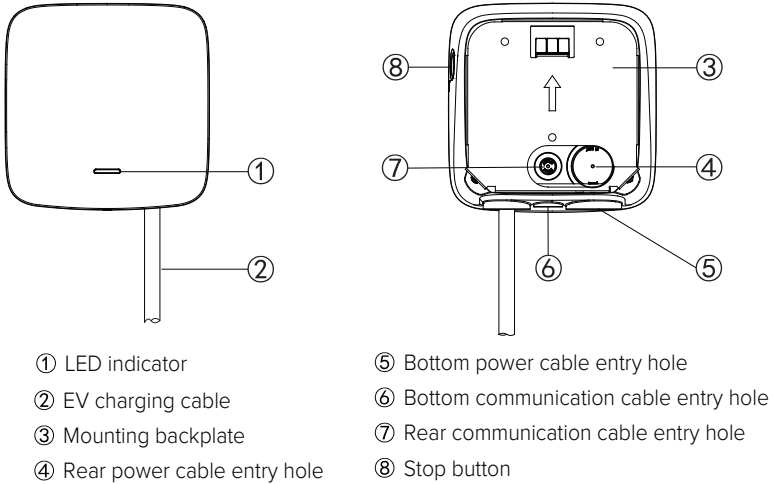

**Note: Ensure the wall or column is vertical.
 A tilt of up to 5° in any direction is acceptable.**

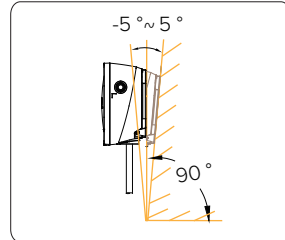

4.2 Earthing System Requirements

The charger integrates PEN fault protection in accordance with IEC 60364-7-722 and BS 7671 Clause 722.411.4.1 (Method 4 – voltage monitoring).

All installations require L, N, and PE conductors to be connected. External RCD protection is required for all earthing systems (see Section 5.2).

Earthing System	Requirement
TN-C-S (PME)	No additional earth electrode required. Charger provides integral PEN fault protection.
TN-S	No additional earth electrode required.
TT	A dedicated local earth electrode (earth rod) must be installed. Earth loop impedance must be verified per local regulations.

Multi-Charger Sites:

All chargers must share a common earth reference in accordance with IEC 60364-7-722. In the event of a PEN conductor fault, the charger will automatically disconnect the supply. For compliance documents, see Compliance Documents at the end of this manual.

5 Installation

5.1 Wall-Mounted Installation

Warning: Isolate supply before drilling.

Before you begin: Confirm the cable entry method:

Bottom entry (standard): Proceed with Step 1 below.

Rear entry (optional): Read Section 5.2 first. The rear knockouts must be opened and cables routed before hanging the charger.

1. Mark hole positions for backplate (3 holes) and plug holder (3 holes). Use a spirit level.

2. Drill holes:

-Backplate: $\varnothing 8$ mm, depth ≥ 50 mm.

-Plug holder: $\varnothing 6$ mm, depth ≥ 40 mm.

3. Insert wall plugs: $\varnothing 8 \times 40$ mm (backplate), $\varnothing 6 \times 30$ mm (plug holder).

4. Secure backplate with ST6 \times 40mm lag screws (3 pcs).

Note: If using rear entry, ensure Section 5.2 (knockout & cable routing) is completed before Step 5.

5. Hang charger onto backplate. Secure from below with ST4.2 \times 9.5mm self-tapping screws (2 pcs).

6. Attach plug holder with ST4.2 \times 35mm lag screws (3 pcs). Place the holder within easy reach for the user. Install the holder after the charger and bottom screws are fully secured. Insert connector into holder.

Post/Pillar Mounting: See QR code at the end of this manual.

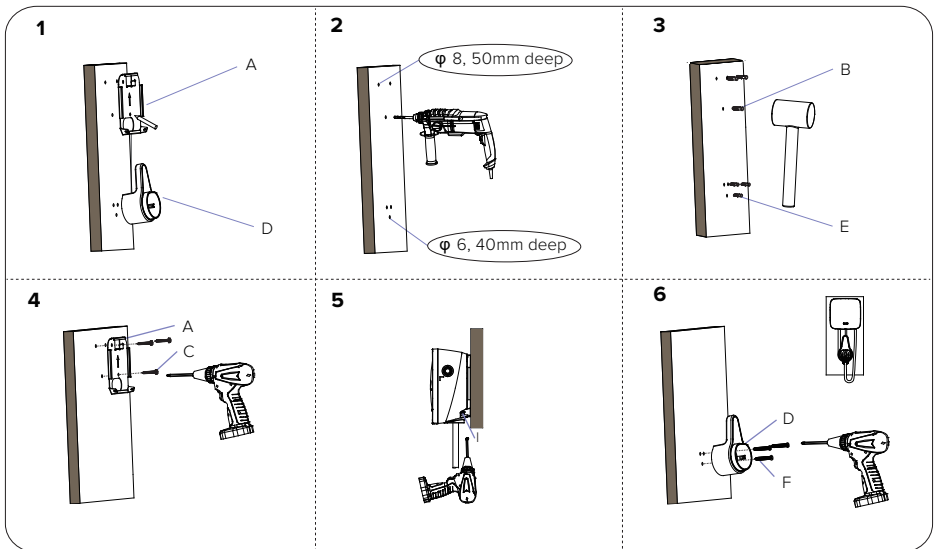

Figure 5-1

5 Installation

5.2 Preparing Cable Entry (Bottom or Rear)

Bottom Entry (Standard)

Power cable → M40 grommet.

Communication/Network cable → M16 grommet.

Rear Entry (Optional)

Complete this section BEFORE hanging the charger (Section 5.1, Step 5). Cables must be pre-routed through wall.

1. Open knockouts on charger rear:

Power: $\phi 40\text{mm}$ (use step drill bit).

Communication: M16 (if required).

2. Install grommets from outside:

M40 grommet in $\phi 40\text{mm}$ hole.

M16 grommet in M16 hole.

3. Route cables: through backplate oval cutout → grommets → into charger.

Cables must be in place before mounting.

4. Return to Section 5.1, Step 5.

Cable Type	Recommended Outer Diameter
3-core (7.3 kW)	12 – 15mm
5-core (11 kW)	14 – 18mm
Communication	5 – 8mm
Ethernet	6 – 8mm

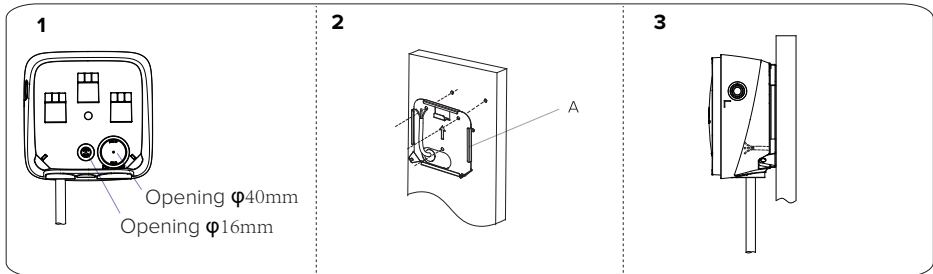

Figure 5-2

5 Installation

5.3 Power Supply Connection

Warning: Verify supply is isolated before proceeding.

RCD & Breaker Requirements:

This charger integrates a 6 mA DC leakage detection device (RDC-DD) .

The external supply circuit must be protected by a Type A RCD ($I_{\Delta n} \leq 30 \text{ mA}$) or a Type B RCD. Type AC RCDs are prohibited.

Model	Breaker	Cable Cross-Section	Cable Type
7.3 kW (1-phase)	C40 (2P)	6 – 10mm ²	H07RN-F or equivalent
11 kW (3-phase)	C20 (4P)	4 – 6mm ²	H07RN-F or equivalent

Procedure

1. Remove the bottom cover using the supplied T10 wrench.
2. Open the wiring cover to access the power terminals.
3. Strip sheath 70mm, strip conductors 10mm. Keep PE 10–15mm longer. Crimp E6012 ferrules onto stripped ends. Then route cable through prepared entry (rubber grommet).
4. Insert ferrules into corresponding terminals (push-fit connection).
-7.3 kW: L, PE, N
-11 kW: L3, L2, L1, PE, N

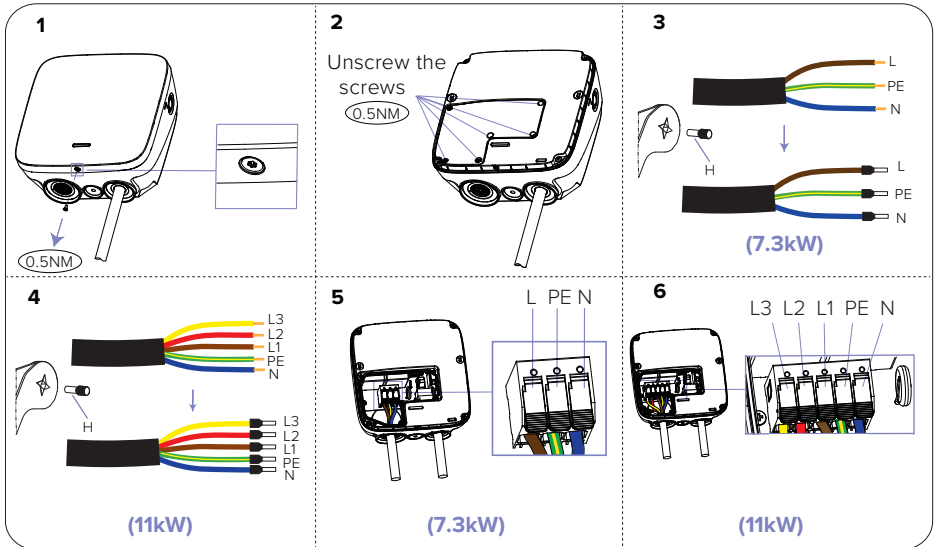

Figure 5-3

5 Installation

5.4 Network connection (Optional)

Default: Wi-Fi. Ethernet optional.

Note: If rear entry used for power, Ethernet must use bottom M16 grommet.

1. Before hanging the charger, route the Ethernet cable through the appropriate entry grommet.
2. Crimp an RJ45 connector onto the cable (not supplied).
3. Insert the RJ45 connector into the Ethernet port and ensure the locking tab engages.

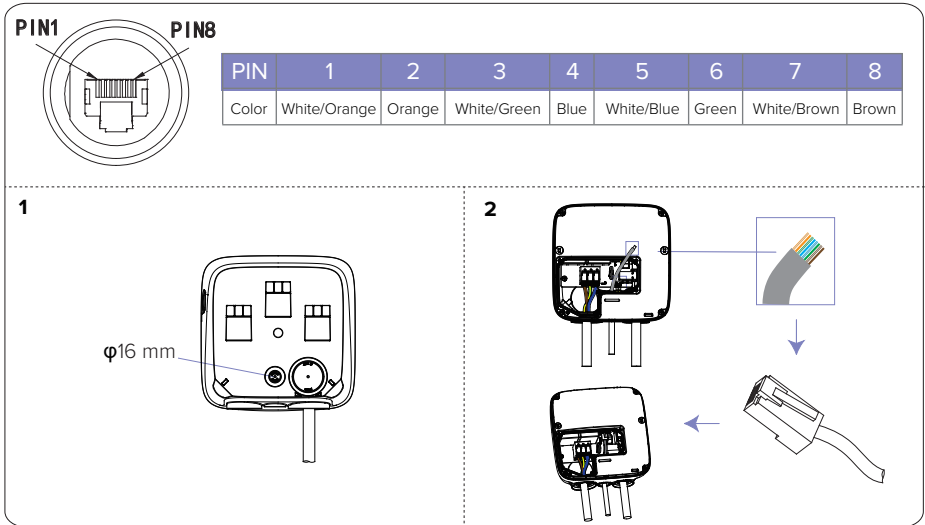

Figure 5-4

5.5 RS485 Connection (Optional)

The RS485 interface is used to connect the charger to an external energy meter or a compatible Fox ESS inverter. This connection is not required for basic charging operation.

Note: If rear entry used for power, RS485 must use bottom M16 grommet.

1. Strip 8mm of insulation from the A and B wires.
2. Crimp the supplied E0508 ferrules onto the stripped ends.
3. Route a twisted pair cable (0.3mm^2) through the M16 rubber grommet.
4. Insert the ferrules into the RS485 A and RS485 B terminals of the signal connector.
4. For meter or inverter wiring details, refer to Section 5.7.

5 Installation

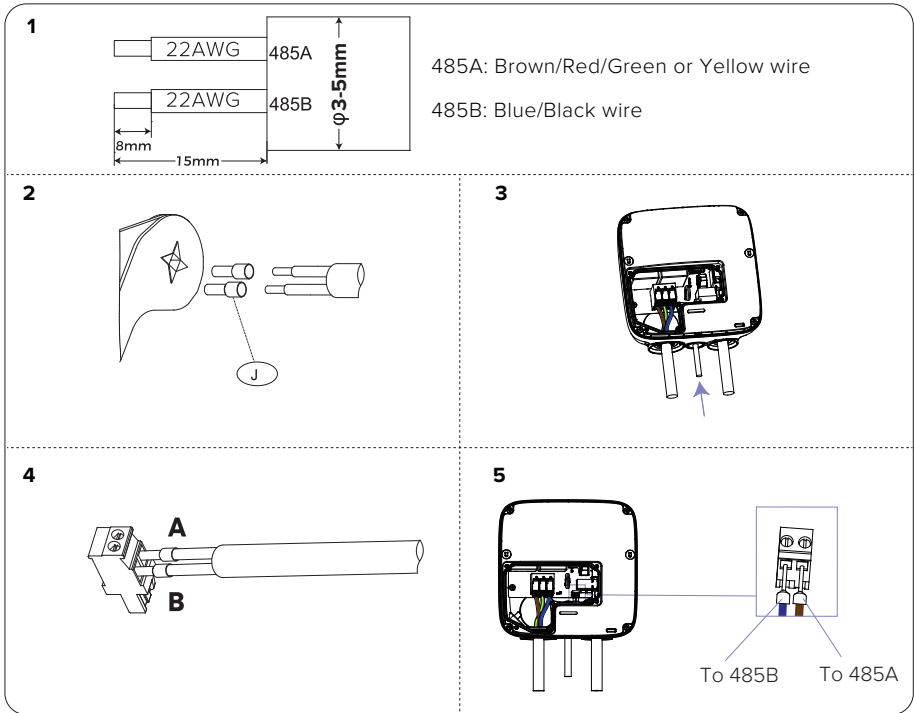

Figure 5-5

Note: please refer to the local cable model and color during actual installation

5.6 Completing the Installation

- 1.Ensure all terminals are securely tightened and no foreign objects remain inside the enclosure.
- 2.Close the wiring cover and secure it with its screws.
- 3.Reattach the bottom cover and tighten the screws using the T10 wrench.
- 4.Restore power at the upstream circuit breaker.
- 5.Observe the LED indicator:
 - Green breathing light: Standby – ready for configuration.
 - Red steady light: Fault detected – check connections.

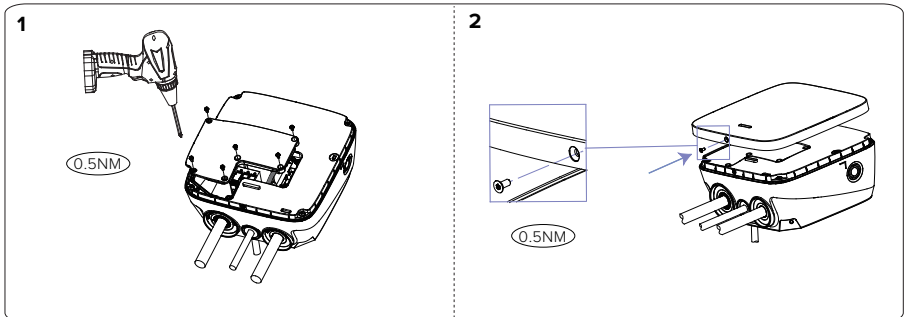

Figure 5-6

6 FoxSwitch App Setup (Installer)

6.1 Device Binding

The FoxSwitch App is used during installation to configure network settings and verify charger functionality.

Prerequisites :

The charger is powered on and in standby mode (green breathing LED).
The installer has received login credentials from the Fox ESS dealer.

Procedure:

1.Download the FoxSwitch app from the Google Play Store or Apple App Store.



- 2.Log in using the installer account provided by your dealer.
- 3.Upon first login, select the country/region where the charger is installed. This ensures connection to the correct cloud server.
- 4.Tap Add Device and scan the QR code on the side of the charger, or enter the serial number manually.
- 5.Once added, the charger appears in the device list. Proceed to Section 6.2 for network configuration.

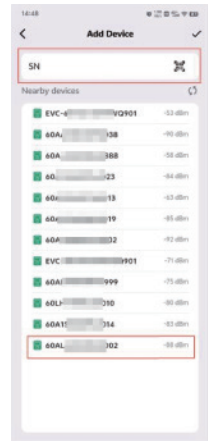
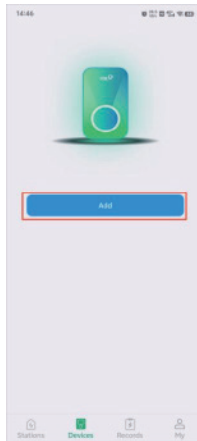
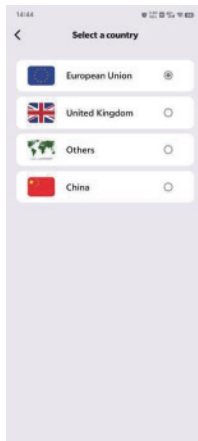
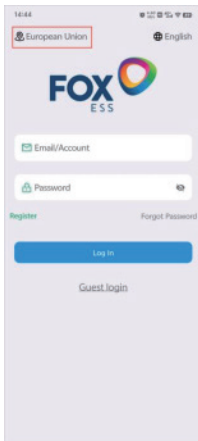

Note: The installer account will automatically unbind from the charger 6 hours after pairing. This does not prevent the end-user from binding the charger to their own account at any time. No manual unbinding is required.

6 FoxSwitch App Setup (Installer)

6.2 Network Configuration

Configure the charger's network connection via the FoxSwitch App.

Prerequisites:

- Charger is added to FoxSwitch App (see Section 6.1).
 - For Ethernet: network cable is installed (see Section 5.4).
 - For Wi-Fi: adequate signal strength at installation site.
- 1.In FoxSwitch, select the charger from the device list.
 - 2.Tap Settings in the upper-right corner, then select Network.
 - 3.Choose connection type:

Wi-Fi:

- Select network or enter SSID manually.
- Enter password and tap Save.

Ethernet (LAN):

- Default: DHCP (recommended).
- For static IP, disable DHCP and enter IP Address, Subnet Mask, Gateway, DNS. Tap Save.
- 4.Wait for connection confirmation. The charger will restart its network interface.

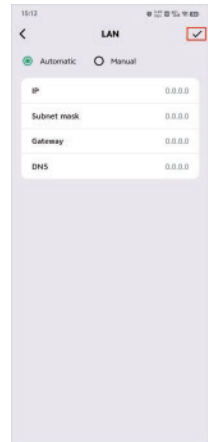
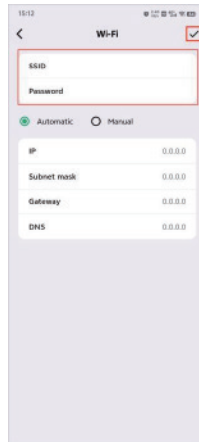
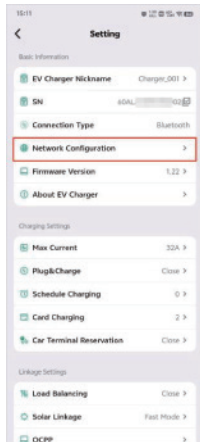
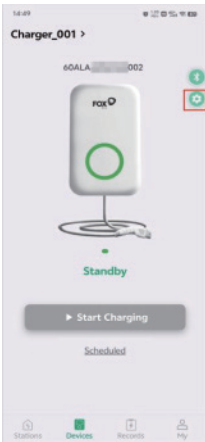

7 Charging Modes and LED Indicators

This section provides a reference for installers to verify charger functionality after installation. For detailed user instructions, refer to the complete user manual.

7.1 Charging Modes

The charger supports three operating modes, configurable via the FoxSwitch App:

Mode	Description	Installer Use
Plug & Charge	Charging starts automatically when EV is plugged in.	Recommended for installation testing.
Controlled	Charging requires authorization via RFID card or App.	For end-user operation.
Locked	Charger is disabled.	Use when service or maintenance is required

Test Charging (Installation Verification):

In FoxSwitch, set the charger to Plug & Charge mode. Connect the charging connector to an EV. Verify that charging initiates and the LED indicator shows blue flowing light. Press the Stop button on the charger side to end the session.

Note: After testing, the charger will remain in Plug & Charge mode. Inform the end-user to switch back to Controlled mode (default) via the FoxSwitch App if authorization control is required, or keep Plug & Charge if preferred.

7.2 LED Indicator Reference

Use the LED indicator to diagnose installation status.

LED State	Meaning	Installer Action
Green breathing	Standby – ready for use.	Normal.
Blue steady	EV plugged in, awaiting authorization (Controlled mode).	Normal if using Controlled mode.
Blue breathing	Authorization granted, but charging is paused.	Check App settings or vehicle status (e.g., schedule set).
Blue flowing	Charging in progress.	Normal.
Green steady	Charging completed.	Normal.
Yellow steady	Charger locked (Locked mode).	Unlock via App if testing.
Red steady	Fault detected – Shutdown Protection.	Check connections, RCD, and earthing. Cycle power.

Compliance Documents

The PEN Fault Protection Statement and UK Smart Charging Regulations Compliance Statement (SI 2021/1467) are available at:

<https://www.fox-ess.com/resource-support/downloads/datasheets?cid=43>



Obtain User Manual QR code

Address: FOXESS CO., LTD. No. 939, Jinhai 3rd Road,
Longwan District, Wenzhou, China

Tel: +86(510) 68092998(General)
+86(510) 68101679 (Sales)

Website: www.fox-ess.com



10-203-00762-01-X