Quick Installation Guide

7.3kW&11kW&22kW AC EV Charger

A7300P1-E-B
A011KP1-E-B
A022KP1-E-B

A7300S1-E-B
A011KS1-E-B
A022KS1-E-B

A7300S-T2S-B
A011KS-T2S-B
A022KS-T2S-B



Contents

1	Notes on This Manual	1
1.1	Scope of Validity	1
1.2	Target Group & Symbols	1
1.3	Explanation of General Symbols	1
2	Safety and Technical Information	2
2.1	Technical Specifications	2
2.2	Safety	3
3	Preparation	4
3.1	Packing List	4
3.2	Tools Required (Not Supplied)	5
4	Product Introduction	6
4.1	Product Overview	6
4.2	Earthing System Requirements	6
5	Installation	7
5.1	Wall-Mounted Installation	7
5.2	Power Supply Connection	7
5.3	Internal Signal Connections (Optional)	9
5.3.1	RS485 Connection	10
5.3.2	CT Connection (7.3 kW Only)	11
5.3.3	Ripple Control Receiver Connection (Germany)	11
5.4	External Network Connections (Optional)	12
5.4.1	LAN Connection	12
5.4.2	4G SIM Card Installation	13
5.5	Completing the Installation	13
5.6	Meter or Inverter Connection (Optional)	14
6	FoxSwitch App Setup (Installer)	15
6.1	Device Binding	15
6.2	Network Configuration	16
7	Charging Modes and LED Indicators	17
7.1	Charging Modes	17
7.2	LED Indicator Reference	17

1 Notes on This Manual

1.1 Scope of Validity

This manual describes the installation and commissioning of the following product models:

A7300P1-E-B	A7300S1-E-B	A7300S-T2S-B
A011KP1-E-B	A011KS1-E-B	A011KS-T2S-B
A022KP1-E-B	A022KS1-E-B	A022KS-T2S-B

Please keep this manual accessible at all times.







1.2 Target Group & Symbols

This manual is intended for use by qualified electricians only.

Symbol	Meaning
Warning	“Warning” indicates a hazardous situation which, if not avoided, could result in death or serious injury.
Note	“Note” provides important tips and guidance.

1.3 Explanation of General Symbols

The following symbols appear on the product label and enclosure:

Symbol	Meaning
	Complies with applicable European Union directives.
	Enclosure may become hot during operation. Avoid contact.
	Danger of electric shock. Do not open cover while energized.
	Complies with applicable United Kingdom regulations.
	Please read the user manual carefully.
	Do not dispose of with household waste. Dispose of at a designated e-waste collection point.
	Complies with applicable Australian and New Zealand regulations.

2 Safety and Technical Information

2.1 Technical Specifications

Rated Values

Parameter	7.3 kW Model	11 kW Model	22 kW Model
Rated supply voltage	230 V AC (1-phase)	400 V AC (3-phase)	400 V AC (3-phase)
Rated current	32 A	16 A	32 A
Rated frequency	50/60 Hz		
Rated output power	7.3 kW	11 kW	22 kW
Protection degree	Body-IP65, Socket-IP55		
Operating temperature	-30 °C to +50 °C		
Altitude	≤ 2000m		

EVSE Classification

Classification Category	Description
Power supply input	AC supply network
Power supply output	AC output
Connection type	Permanently connected
Environmental conditions	Indoor and outdoor
Access	Restricted access (installation) / Non-restricted access (operation)
Mounting method	Wall-mounted or post / pillar-mounted (optional)
Ventilation	Not supported / Not applicable for AC charging (Mode 3)
Protection against electric shock	Class I
Charging mode	Mode 3

2 Safety and Technical Information

2.2 Safety

EV chargers are designed and tested in compliance with **EN IEC 61851-1**.

Installation and maintenance shall be performed **only by a certified electrician** in accordance with local wiring regulations.

Before installation, inspect the unit for transport damage. Do not install a damaged unit.

Unauthorized removal of protective devices, improper use, incorrect installation, or improper operation may result in serious safety hazards, electric shock, or equipment damage.

Do not install in adverse environments: near flammables or explosives, in corrosive or desert environments, or in areas with extreme temperatures or high humidity.

Do not operate the charger if any safety device is inoperative or has been disabled.

Always wear appropriate **Personal Protective Equipment (PPE)**, including **electrically insulated gloves** and **safety goggles**.

All repair work must utilize only approved spare parts and be performed by a licensed contractor or authorized service provider.

RCD Requirement: This charger integrates a **6 mA DC leakage detection device (RDC-DD)** compliant with **IEC 62955**. The external supply circuit must be protected by a **Type A RCD** ($I\Delta n \leq 30 \text{ mA}$) or a **Type B RCD**. **Type AC RCDs are prohibited.**

Earthing: This product includes protection against PEN conductor faults for **TN-C-S (PME)** systems. For **TT systems**, a local earth electrode must be installed in accordance with local regulations. Refer to Section 4.2 for details.

3 Preparation

3.1 Packing List

Verify all items are present before installation.

A. Wall Mounting Kit

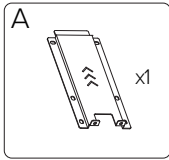

Mounting backplate

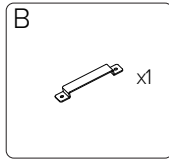

Mounting bracket

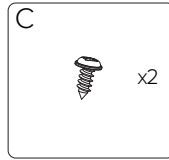

Self-tapping Screw
(ST4.2*9.5mm)

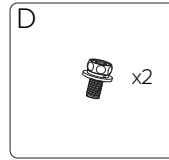

Screw Assembly
(M4*10mm)

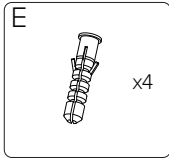

Wall plug
($\varnothing 8 \times 40$ mm)

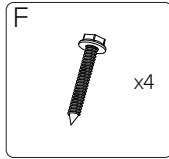

Lag screw
(ST6*40mm)

B. Electrical Connection Accessories

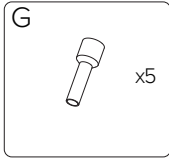

Ferrule terminal
(EVN10-12)

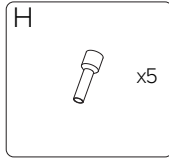

Ferrule terminal
(EVN6012)

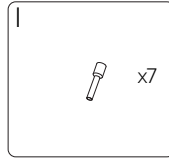

Ferrule terminal
(EVN0508)

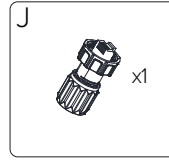

RJ45 Connectors

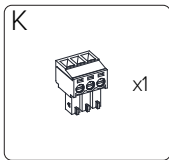

Plug-in connector
Ripple control (3-pin)

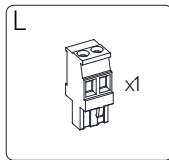

Plug-in connector
RS485 (2-pin)

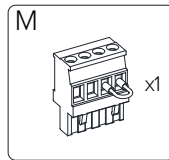

Plug-in connector
CT (4-pin, single-phase)

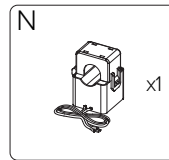

CT Clamp
(for single - phase)

C. Documentation & Accessories

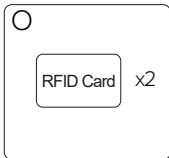

RFID Card

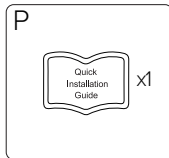

Quick Installation
Guide

3 Preparation

3.2 Tools Required (Not Supplied)

The following tools are required for installation. They are not included in the packaging:



Electric drill



Masonry drill bits: $\phi 8\text{mm}$



Insulated gloves (PPE)



Spirit level



Markers

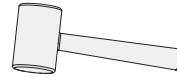

Hammer



Cross-head screwdriver

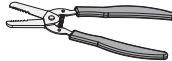

Wire stripper

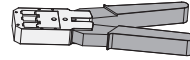

RJ45 crimping tool
(if Ethernet connection
is used)



Multimeter (for supply
isolation verification)



Crimping pliers
(for E6012 and
E0508 ferrules)



Safety goggles

4 Product Introduction

4.1 Product Overview

Refer to the illustration below for component identification.

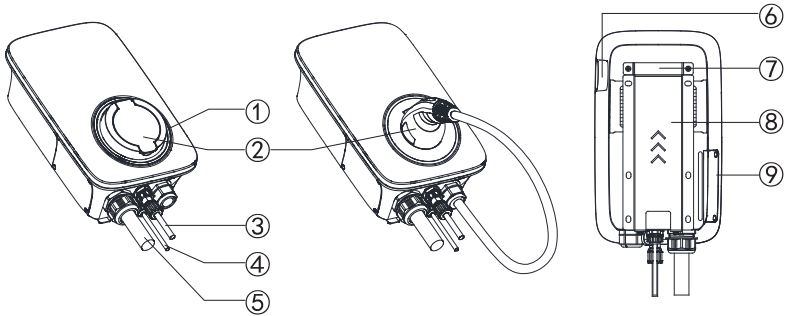

- | | |
|--|------------------------|
| ① LED Indicator | ⑤ Incoming Cable Entry |
| ② Charging Plug (tethered cable version)
Charging Socket (socket version) | ⑥ Stop Button |
| ③ RJ45 Communication Port | ⑦ Mounting Bracket |
| ④ RS485 Communication Port | ⑧ Mounting Backplate |
| | ⑨ Side Cover |

**Note: Ensure the wall or column is vertical.
A tilt of up to 5° in any direction is acceptable.**

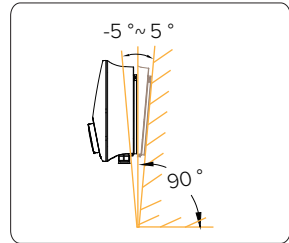

4.2 Earthing System Requirements

The charger integrates PEN fault protection in accordance with IEC 60364-7-722 and BS 7671 Clause 722.411.4.1 (Method 4 – voltage monitoring).

All installations require L, N, and PE conductors to be connected. External RCD protection is required for all earthing systems (see Section 5.2).

Earthing System	Requirement
TN-C-S (PME)	No additional earth electrode required. Charger provides integral PEN fault protection.
TN-S	No additional earth electrode required.
TT	A dedicated local earth electrode (earth rod) must be installed. Earth loop impedance must be verified per local regulations.

Multi-Charger Sites:

All chargers must share a common earth reference in accordance with IEC 60364-7-722. In the event of a PEN conductor fault, the charger will automatically disconnect the supply. For compliance documents, see Compliance Documents at the end of this manual.

5 Installation

5.1 Wall-Mounted Installation

Warning: Isolate supply before drilling.

Procedure

1. Mark four hole positions on the wall using the installation positioning card. Use a spirit level to ensure alignment.
2. Drill holes: $\varnothing 8\text{mm}$, depth $\geq 50\text{mm}$. Clean the holes of dust and debris.
3. Insert $\varnothing 8 \times 50\text{mm}$ wall plugs into the holes. Tap flush with the wall surface using a rubber hammer.
4. Secure the mounting backplate to the wall using the four ST6 \times 40mm lag screws.
5. Attach the mounting bracket to the rear of the charger body using the two M4 \times 10mm screw assemblies.
6. Hang the charger (with bracket) onto the backplate and tighten the two ST4.2 \times 9.5mm self-tapping screws to complete the installation.

Post/Pillar Mounting: See QR code at the end of this manual.

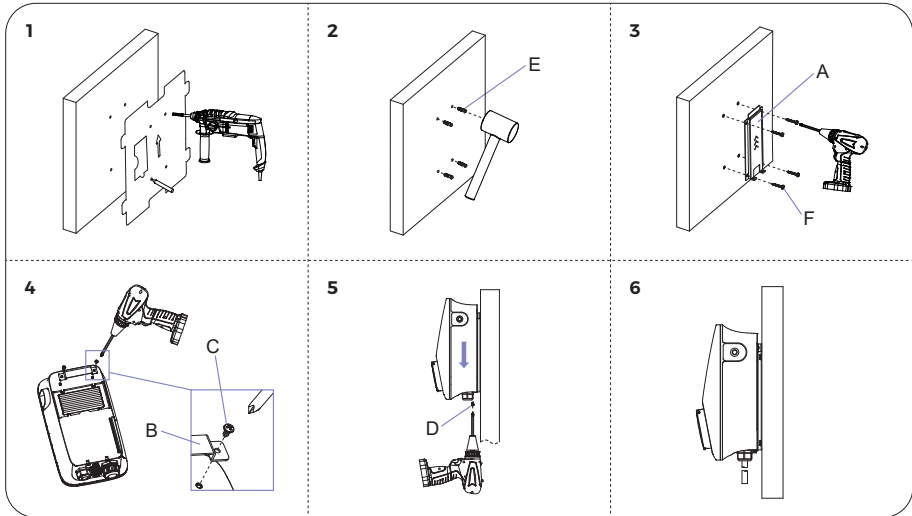

Figure 5-1

5.2 Power Supply Connection

Warning: Verify supply is isolated before proceeding.

RCD & Breaker Requirements: This charger integrates a **6 mA DC leakage detection device (RDC-DD)**. The external supply circuit must be protected by a **Type A RCD** ($I\Delta n \leq 30\text{ mA}$) or a **Type B RCD**. **Type AC RCDs are prohibited.**

Model	Breaker	Cable Cross-Section	Cable Type
7.3 kW (1-phase)	C40 (2P)	6 – 10mm ²	H07RN-F or equivalent
11kW (3-phase)	C20 (4P)	4 – 6mm ²	H07RN-F or equivalent
22 kW (3-phase)	C40 (4P)	6 – 10mm ²	H07RN-F or equivalent

5 Installation

Procedure

1. **Prepare cable:** Trim cables to **50mm**, strip insulation **10mm**. Keep PE **10–15mm longer**. Crimp **EVN10-12** or **EVN6012** ferrule terminals onto stripped ends as appropriate for the cable cross-section.
2. Unscrew gland nut and pierce wire-through hole.
3. Open side cover. Insert cable through gland into charger. Connect conductors to terminals per table. Tighten terminal screws.
4. Tighten gland nut to secure cable.
5. Leave side cover open if installing communication connections. Otherwise, close the side cover.

Refer to local cable colour codes during actual installation.

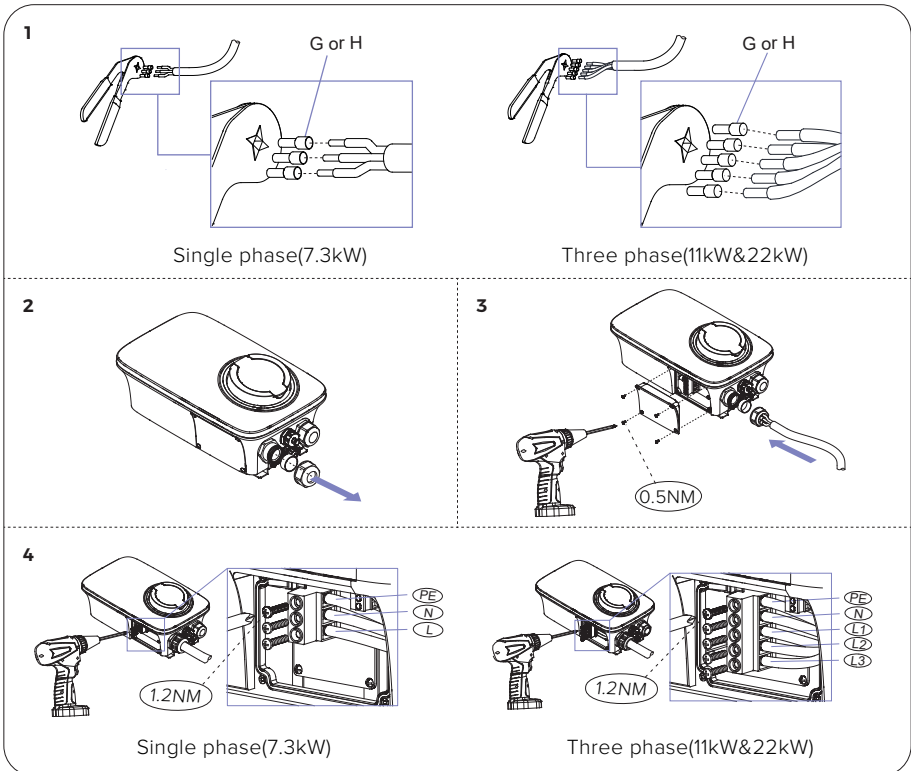

Figure 5-2

5 Installation

5.3 Internal Signal Connections (Optional)

Warning: Complete all internal signal connections before closing the side cover (see Section 5.2, Step 5).

The connector locations on the PCB are shown below.

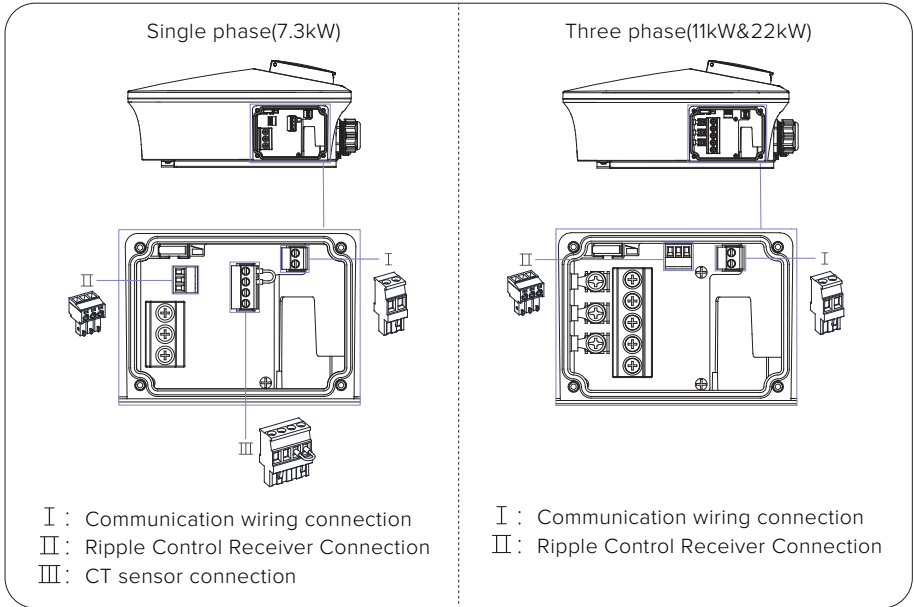

Figure 5-3

All signal terminals are plug-in connectors supplied in the accessory kit. For all connections:

- 1.Route the cable through the signal cable gland to the side wiring area.
- 2.Crimp the ferrule terminal onto the cable end.
- 3.Insert the ferrule into the plug-in connector and tighten the screw.
- 4.Plug the connector into the corresponding socket on the PCB.

Cable preparation for all signal connections: Trim to **15mm**, strip insulation **8mm**. All signal cables use 0.3mm² wire.

See Figure 5-3 for the side wiring area layout and PCB connector positions.

5 Installation

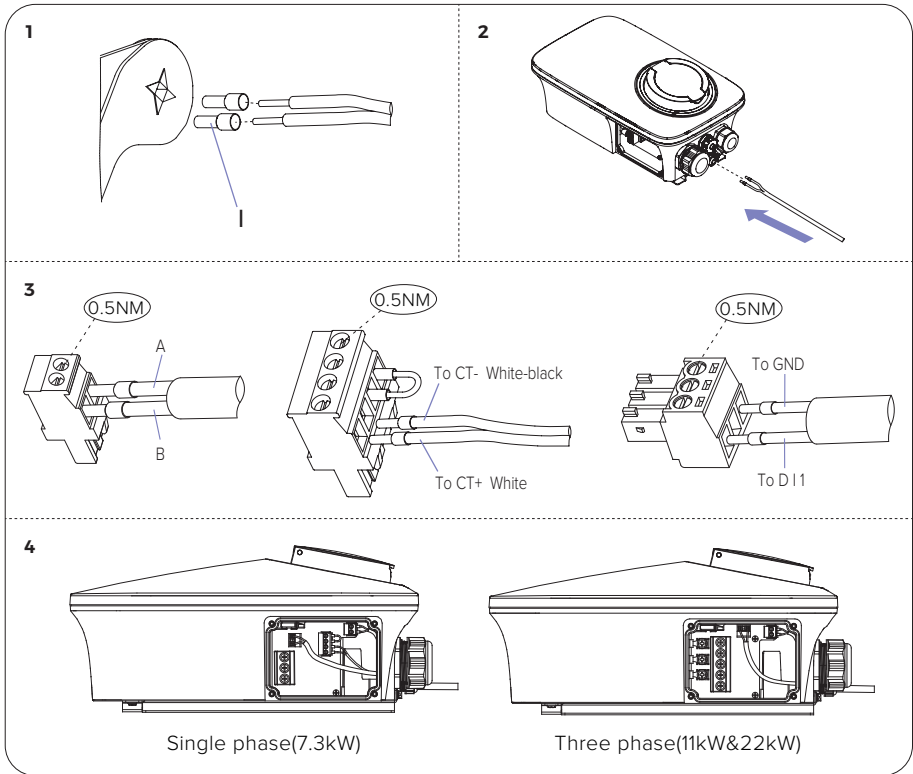

Figure 5-4

5.3.1 RS485 Connection

The RS485 interface connects the charger to an external energy meter or a compatible Fox ESS inverter.

Connector type: 2-pin plug-in connector.

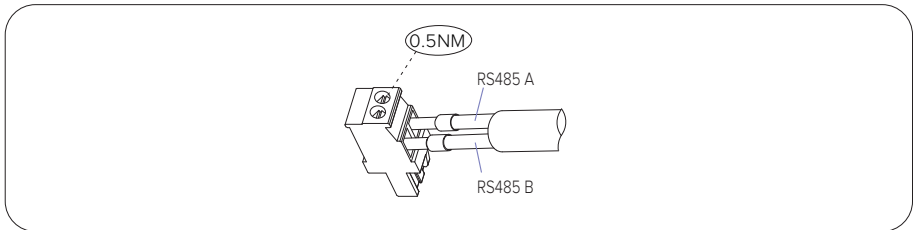

Figure 5-5

For connection details to an external meter or inverter, see Section 5.6.
See Figure 5-4 for the complete RS485 wiring illustration.

5 Installation

5.3.2 CT Connection (7.3 kW Only)

Note: Available on 7.3 kW single-phase models only. Provides the same energy monitoring function as an external meter.

The CT sensor clamps around the incoming grid supply cable. The extension lead connects via a 4-pin plug-in connector. Only 2 pins (CT+, CT-) are used.

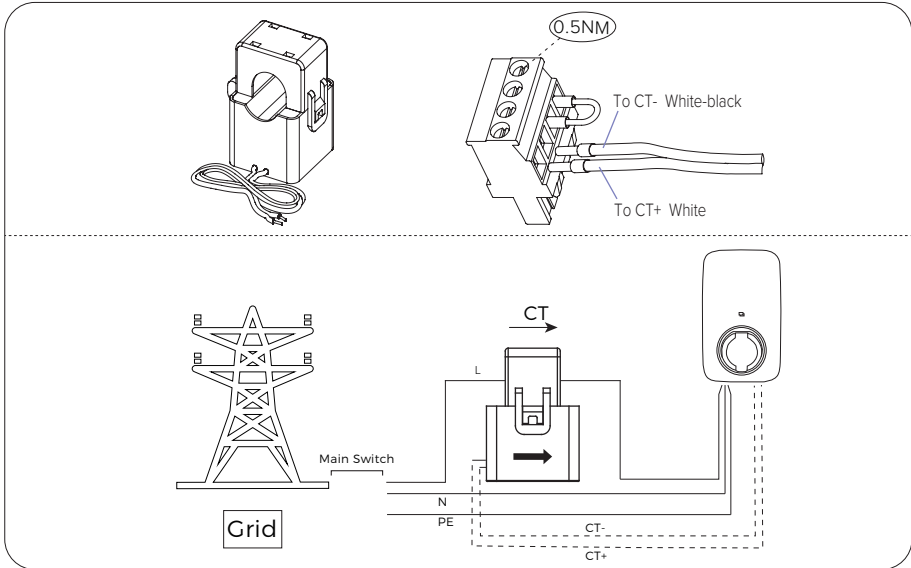

Figure 5-6

Clamp the CT sensor around the incoming grid supply cable with the arrow pointing towards the load.

See Figure 5-4 for the complete CT wiring illustration.

5.3.3 Ripple Control Receiver Connection (Germany)

For installations subject to §14a EnWG (Germany). Allows grid operator load curtailment via a dry contact signal.

Connector type: 3-pin plug-in connector. Only DI1 and GND are used. DI2 is reserved.

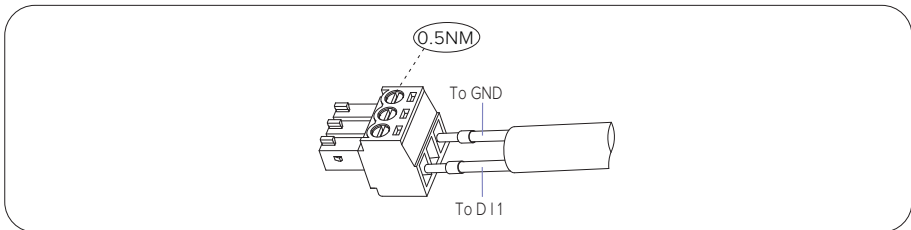

Figure 5-7

Note: For receiver-end wiring, see the third-party manual.

See Figure 5-4 for the complete ripple control wiring illustration.

5 Installation

5.4 External Network Connections (Optional)

The charger supports Wi-Fi as the standard (and recommended) connection method. LAN is also available as a standard interface, while 4G is an optional connectivity method (hardware availability varies by model).

Note: 4G hardware availability is model-dependent. Verify that the charger variant supports 4G before installation.

5.4.1 LAN Connection

The RJ45 connector is supplied in the accessory kit. It features two threaded locking rings for waterproof sealing:

Front locking ring: Secures the RJ45 plug to the charger socket.

Rear locking ring: Secures the external cable.

1. Pass the network cable through the rear locking ring and front locking ring.
2. Crimp the RJ45 plug onto the cable end.
3. Unscrew the dust cover from the Ethernet port. Insert the RJ45 plug.
4. Tighten the front locking ring to secure the RJ45 plug to the charger socket.
5. Tighten the rear locking ring to secure the external cable and maintain the waterproof seal.

See Figure 5-8 for Ethernet port location and connector detail.

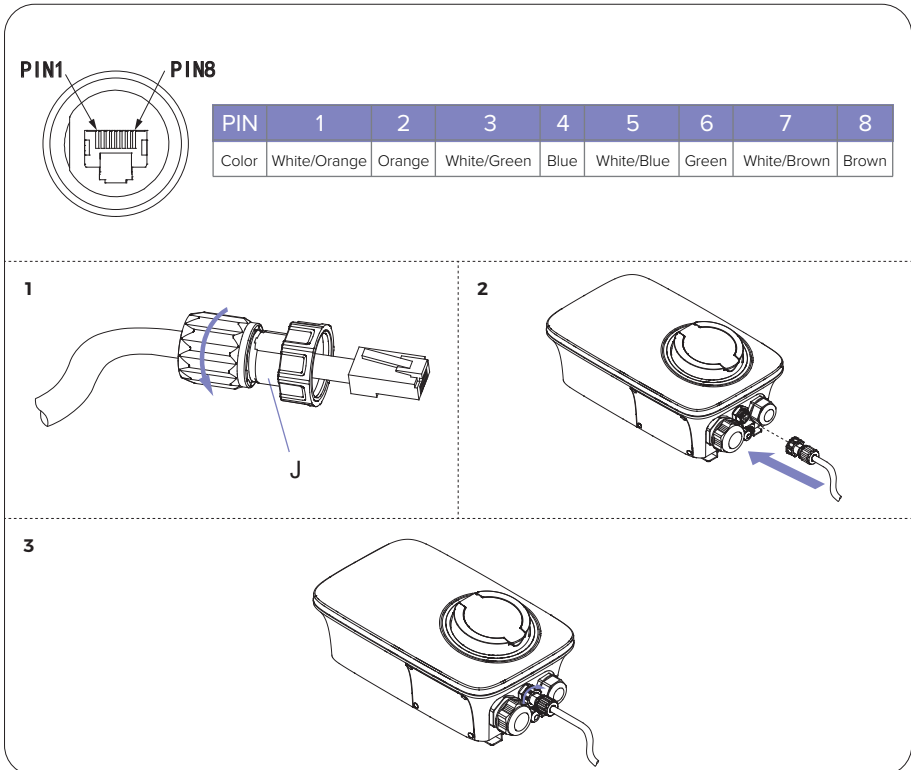

Figure 5-8

5 Installation

5.4.2 4G SIM Card Installation

Note: This function is only available on models equipped with 4G hardware.

1. Use a flat-head screwdriver to push in the tabs connecting the face cover. There are 10 tabs in total. Open the face cover.
2. Locate the SIM card slot on the communication module. Insert the SIM card with the correct orientation.
3. Close the SIM card cover. Reattach the face cover to complete the installation.

See Figure 5-9 for SIM card slot location and insertion orientation.

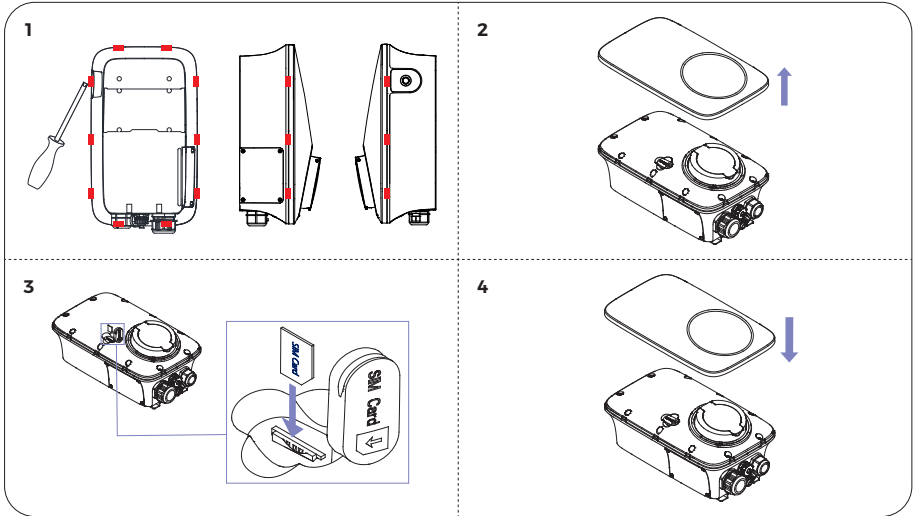

Figure 5-9

5.5 Completing the Installation

1. Check all terminals are tight and no foreign objects remain inside.
2. Verify that all grommets and glands are correctly installed.
3. Close the side cover and secure with screws.
4. Restore power at the upstream circuit breaker.
5. Observe the LED indicator:
 - Green breathing light: Standby – ready for configuration.
 - Red steady light: Fault detected – check connections.

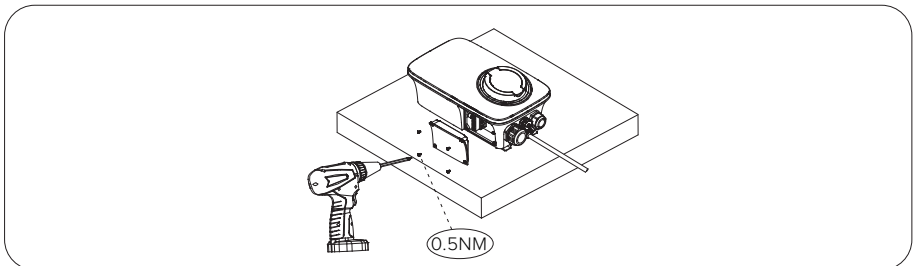

Figure 5-10

5 Installation

5.6 Meter or Inverter Connection (Optional)

The charger can connect to an external energy meter or a compatible Fox ESS inverter for load management and solar integration. These connections are not required for basic charging operation.

Connection Overview:

Meter Connection (Direct or CT): See Figure 5-11.

The charger communicates with the meter via RS485 to monitor energy consumption and generation. The inverter is also connected to the meter, but does not directly connect to the charger.

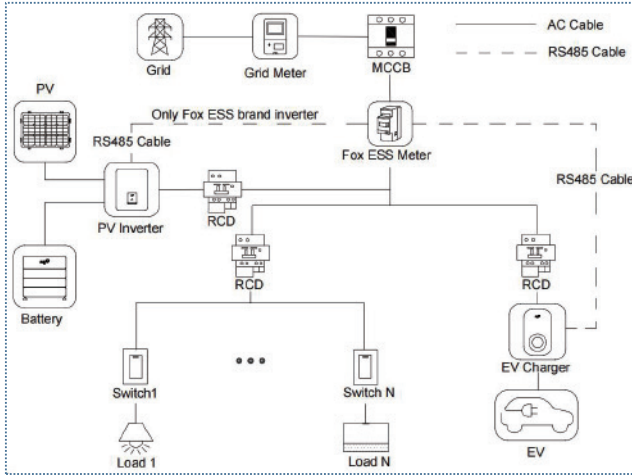

Figure 5-11

Inverter Connection (Fox ESS only): See Figure 5-12.

The charger communicates directly with the inverter via RS485. In this configuration, the inverter must still be connected to a meter or CT on its side.

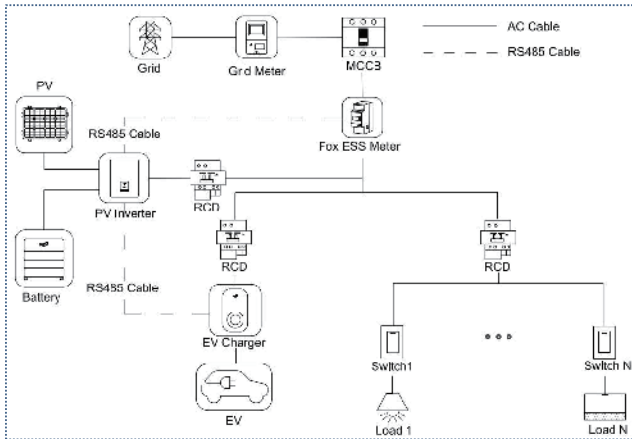

Figure 5-12

For detailed wiring diagrams and functional operation instructions, scan the QR code at the end of this manual to obtain the Energy Management Manual.

6 FoxSwitch App Setup (Installer)

6.1 Device Binding

The FoxSwitch App is used during installation to configure network settings and verify charger functionality.

Prerequisites :

The charger is powered on and in standby mode (green breathing LED).
The installer has received login credentials from the Fox ESS dealer.

Procedure:

1.Download the FoxSwitch app from the Google Play Store or Apple App Store.



- 2.Log in using the installer account provided by your dealer.
- 3.Upon first login, select the country/region where the charger is installed. This ensures connection to the correct cloud server.
- 4.Tap Add Device and scan the QR code on the side of the charger, or enter the serial number manually.
- 5.Once added, the charger appears in the device list. Proceed to Section 6.2 for network configuration.

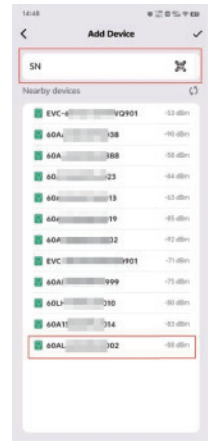
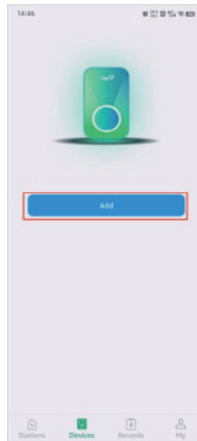
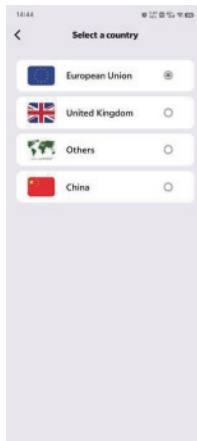
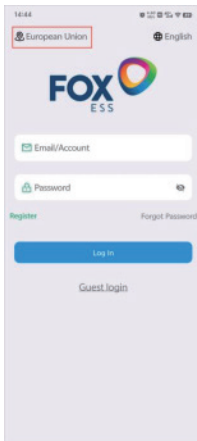

Note: The installer account will automatically unbind from the charger 6 hours after pairing. This does not prevent the end-user from binding the charger to their own account at any time. No manual unbinding is required.

6 FoxSwitch App Setup (Installer)

6.2 Network Configuration

Configure the charger's network connection via the FoxSwitch App.

Prerequisites :

- Charger is added to FoxSwitch App (see Section 6.1).
 - For Ethernet: network cable is installed (see Section 5.4).
 - For Wi- Fi: adequate signal strength at installation site.
- 1.In FoxSwitch, select the charger from the device list.
 - 2.Tap Settings in the upper-right corner, then select Network.
 - 3.Choose connection type:

Wi-Fi:

- Select network or enter SSID manually.
- Enter password and tap Save.

Ethernet (LAN):

- Default: DHCP (recommended).
- For static IP, disable DHCP and enter IP Address, Subnet Mask, Gateway, DNS. Tap Save.
- 4.Wait for connection confirmation. The charger will restart its network interface.

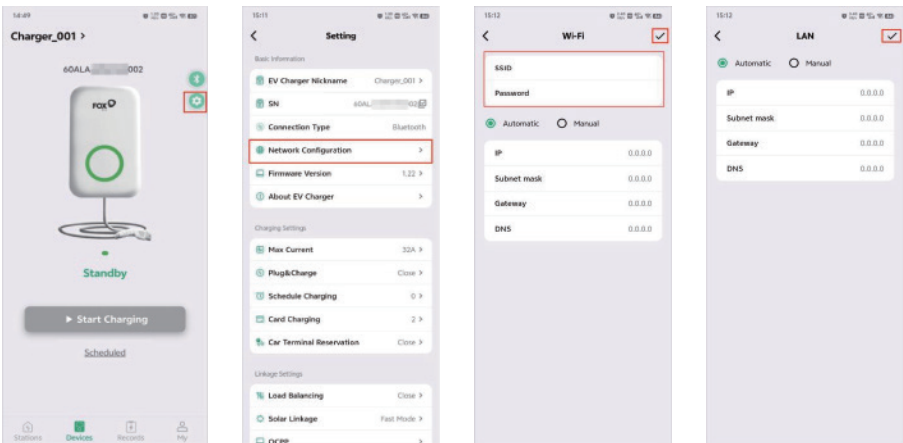

7 Charging Modes and LED Indicators

This section provides a reference for installers to verify charger functionality after installation. For detailed user instructions, refer to the complete user manual.

7.1 Charging Modes

The charger supports three operating modes, configurable via the FoxSwitch App:

Mode	Description	Installer Use
Plug & Charge	Charging starts automatically when EV is plugged in.	Recommended for installation testing.
Controlled	Charging requires authorization via RFID card or App.	For end-user operation.
Locked	Charger is disabled.	Use when service or maintenance is required

Test Charging (Installation Verification):

In FoxSwitch, set the charger to Plug & Charge mode. Connect the charging connector to an EV. Verify that charging initiates and the LED indicator shows blue flowing light. Press the Stop button on the charger side to end the session.

Note: After testing, the charger will remain in Plug & Charge mode. Inform the end-user to switch back to Controlled mode (default) via the FoxSwitch App if authorization control is required, or keep Plug & Charge if preferred.

7.2 LED Indicator Reference

Use the LED indicator to diagnose installation status.

LED State	Meaning	Installer Action
Green breathing	Standby – ready for use.	Normal.
Blue steady	EV plugged in, awaiting authorization (Controlled mode).	Normal if using Controlled mode.
Blue breathing	Authorization granted, but charging is paused.	Check App settings or vehicle status (e.g., schedule set).
Blue flowing	Charging in progress.	Normal.
Green steady	Charging completed.	Normal.
Yellow steady	Charger locked (Locked mode).	Unlock via App if testing.
Red steady	Fault detected – Shutdown Protection.	Check connections, RCD, and earthing. Cycle power.

Compliance Documents

The PEN Fault Protection Statement and UK Smart Charging Regulations Compliance Statement (SI 2021/1467) are available at:

<https://www.fox-ess.com/resource-support/downloads/datasheets?cid=43>



Obtain User Manual QR code

Address: FOXESS CO., LTD. No. 939, Jinhai 3rd Road,
Longwan District, Wenzhou, China

Tel: +86(510) 68092998(General)
+86(510) 68101679 (Sales)

Website: www.fox-ess.com



10-203-00760-00-X