

# **G-MAX Plus Series ESS**

## **Quick Installation Guide**

**Issue: V1.1**

**Date: 2026-03-18**

**FOXESS CO., LTD.**



## Notice

1. The information in this document may not be modified, copied or reproduced, in whole or in part, without the prior written permission of FOXESS CO., LTD. All information in this document is provided to the best of our knowledge and efforts, but does not constitute a warranty of any kind, express or implied. You can download quick guide and user manual by scanning the QR code.



2. Only certified electricians are allowed to operate the device. Operation personnel must wear proper personal protective equipment (PPE).

3. Before installing the device, check that the package contents are intact and complete against the packing list. If any damage is found or any component is missing, contact your dealer.

4. The device damage caused by the violation of instructions in this document is not covered under warranty.

## 1 Packing List

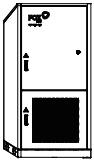

A



B



C



D



E

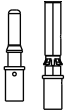

F

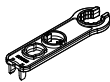

G



H



I



J



K

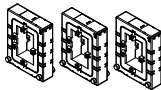

L

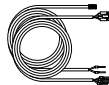

M

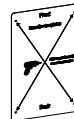

N



O

OBJ	QTY	DESC	OBJ	QTY	DESC
A	1	G-MAX Plus	I	4	PACK MSD
B	4	Eyebolt	J	1	EPS-PE Terminal
C	4	Sealing Clay	K	1	Meter
D	12	AC Terminal (SC120-10 300A×12)	L	3	CT
E	16/32	DC Connector (4 MPPT: Positive×8, Negative×8; 8 MPPT: Positive×16, Negative×16)	M	2	Meter/CT Cable (5m)
F	16/32	DC Pin Plug (4 MPPT: Positive×8, Negative×8; 8 MPPT: Positive×16, Negative×16)	N	1	Drilling Template
G	1	DC Connector Removal Tool	O	1	Quick Installation Guide
H	5	Ground Terminal (RNB38-8S 150A×5)			

## 2 Required Tools

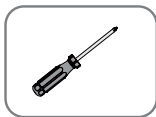

Phillips-Head  
Screwdriver

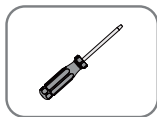

Flat-Head  
Screwdriver



Wire Stripper

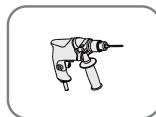

Impact Drill  
(Bit: Φ 16mm)

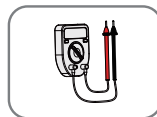

Multimeter  
(≥1500 V dc)

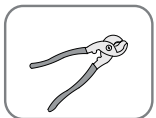

Wire Snips

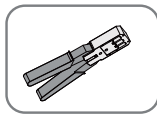

RJ45 Crimping  
Pliers

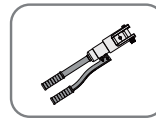

Hydraulic  
Clamp

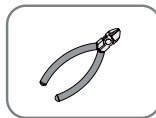

Tweezers

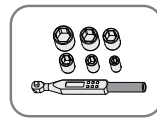

Socket Spanner  
(M4~M12)

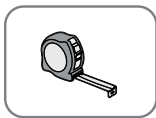

Tape



Marker

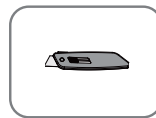

Utility Knife

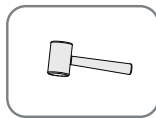

Rubber Mallet



Cable Ties



Wire Crimper



Insulated Ladder



Crane

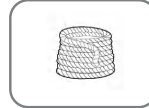

Sling  
(Length>2000mm\*4)



Electric Forklift



Heat Gun



**DANGER:**

**Special care must be taken to protect personal safety.**

PPE must be worn during transfer and installation.



**WARNING:**

Please use proper protective measures, such as foam or protective cloth, keep the unit well protected from hard objects that may damage their exterior appearance or body during handling and installation.

**3 Handling**

**3.1 Forklift Handling**

Forklift handling capacity:  $\geq 3t$

Adjust the forklift tine width so that the load's center of gravity is centered between the tines.

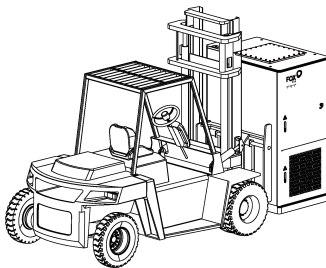

Side

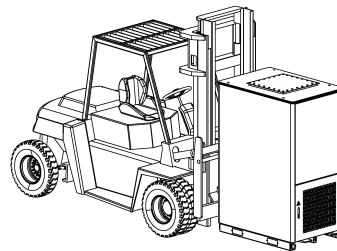

Back

### 3.2 Crane Handling

Use slings (min. 3t capacity each). Secure the cabinet, with hook  $\geq 1\text{m}$  from the cabinet top and tilt maintained under  $10^\circ$ .

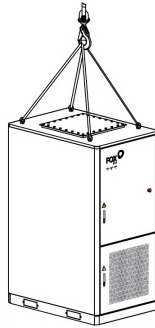

## 4 Installation Steps

### 4.1 Space Requirement

#### 4.1.1 Single Unit

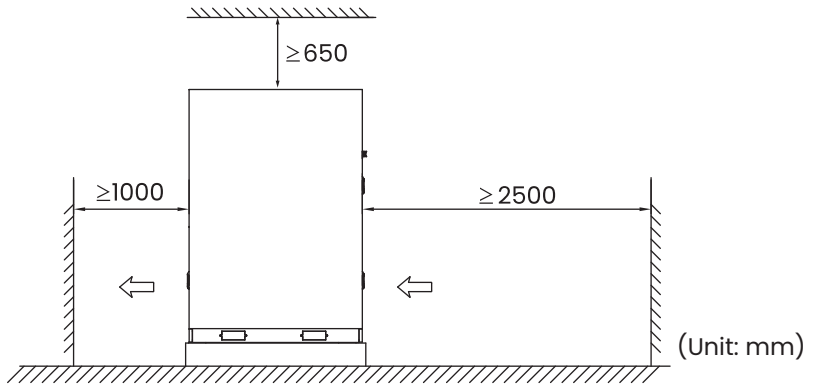

#### NOTE:



The unit is not recommended for indoor use. For indoor installation, compliance with local regulations is required. Ensure the ambient temperature is  $\leq 45^\circ\text{C}$  with adequate ventilation.

4.1.2 Parallel Units

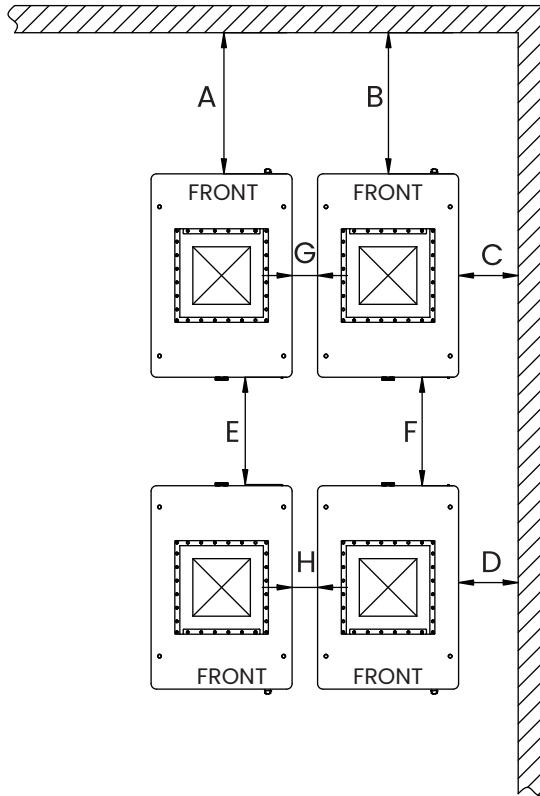

$A=B=2500\text{mm}$ ,  $C=D=10\text{mm}$ ,  $E=F=1000\text{mm}$ ,  $G=H=0\text{mm}$

## 4.2 Foundation Requirement

Items	Requirements
Base Surface	Be concrete or non-combustible, level, firm, and load-bearing.
Load Capacity	Designed for total equipment weight; if the weight exceeds 3t, reassess and reinforce the foundation accordingly.
Connections	Adjusted based on site conditions. On hard surfaces, secure using welding or bolting.
Water Protection	Keep base above highest historical water level.

The following foundation drawings are for reference only.

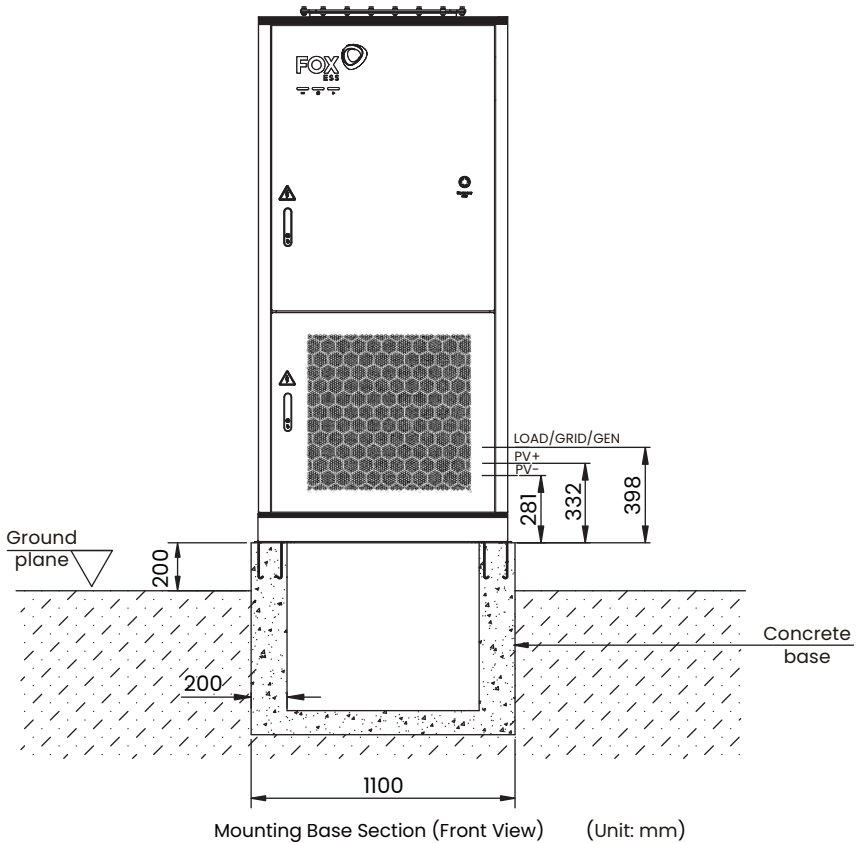

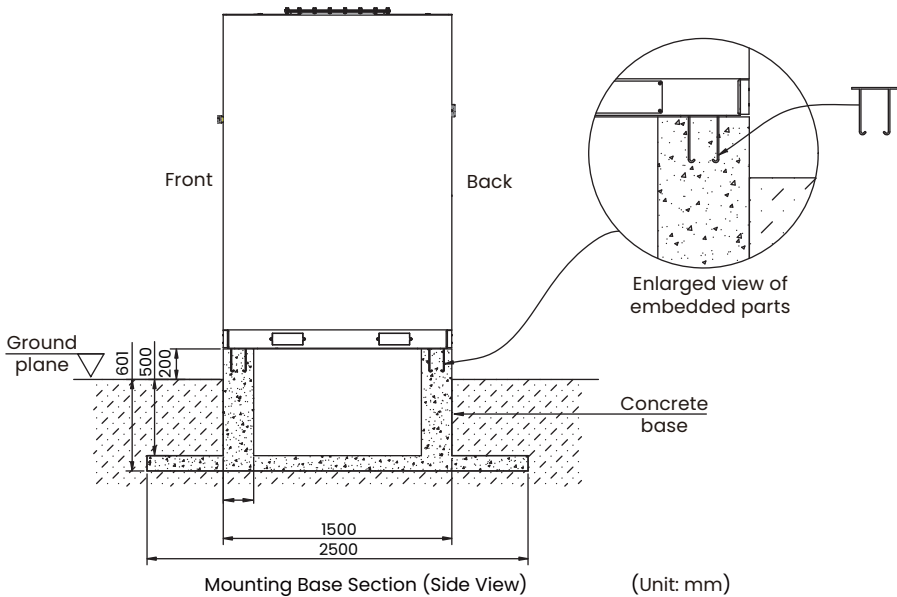

- ① - PV cable outlet
- ② - Load cable outlet
- ③ - Grid cable outlet
- ④ - GEN cable outlet
- ⑤ - COM cable outlet

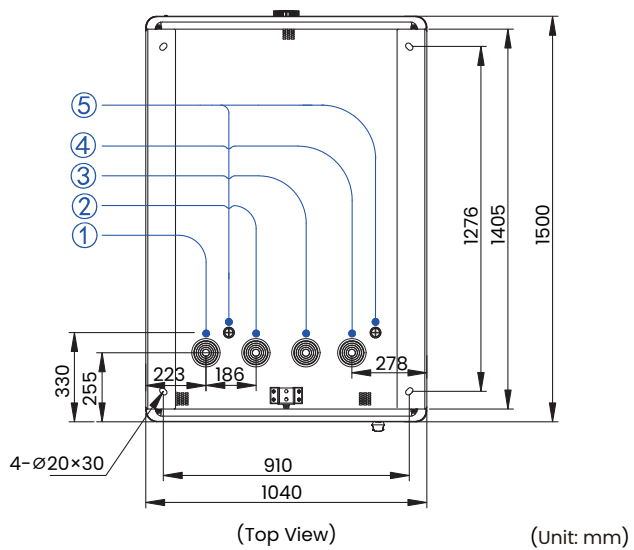

# 5 System Wiring Diagram

## 5.1 Whole-home Backup

Whole-home Backup (DC Couple)

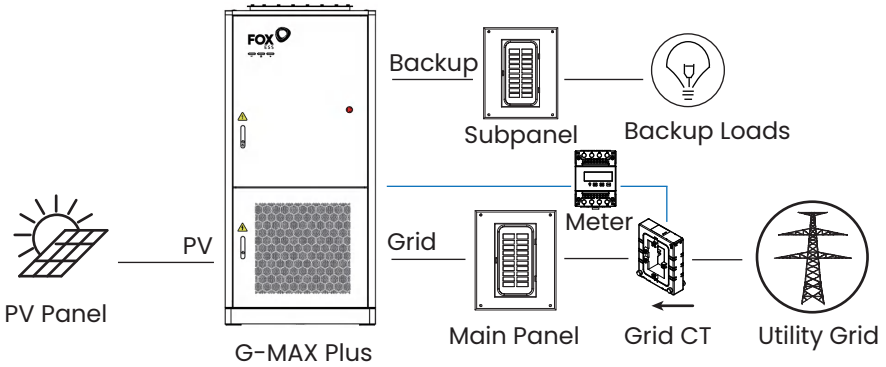
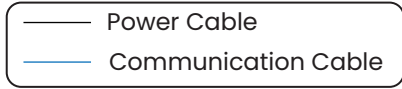

Whole-home Backup (AC Couple)

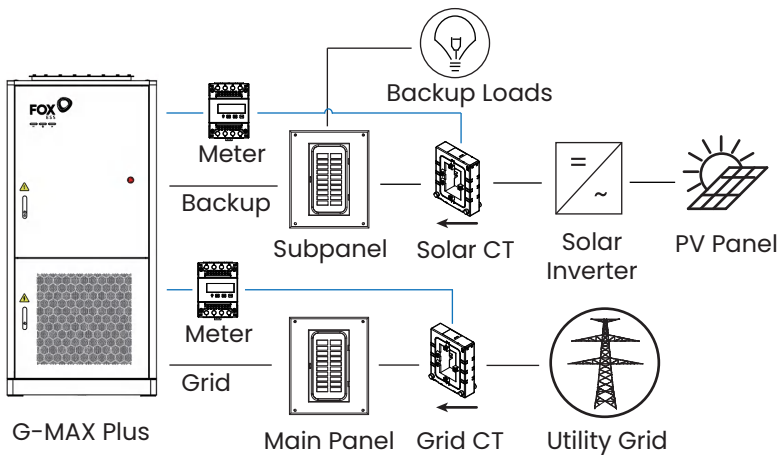
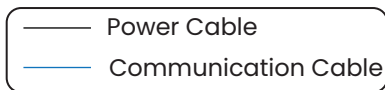

## 5.2 Partial-home Backup

### Partial-home Backup (DC Couple)

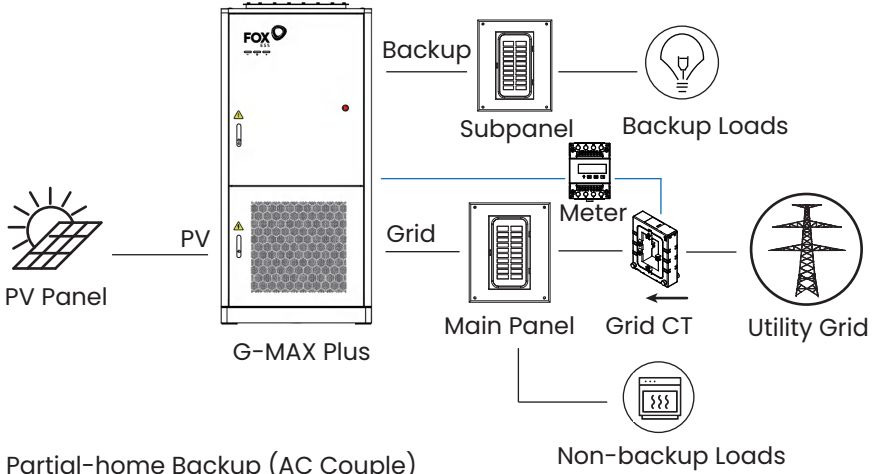
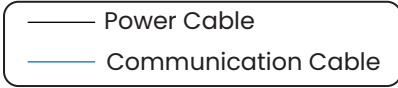

### Partial-home Backup (AC Couple)

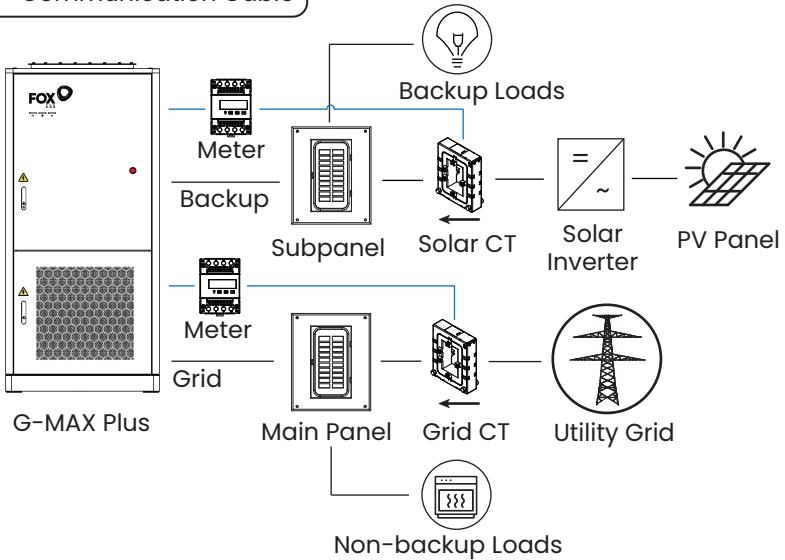
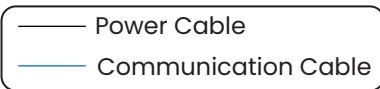

## 6 System Wiring Steps

### 6.1 PV Wiring

- ① Turn off **DC SWITCH 1** and **DC SWITCH 2**.

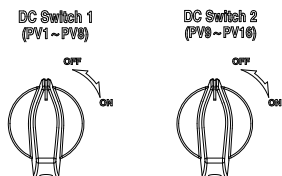

③

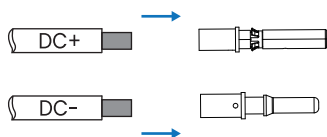

⑤

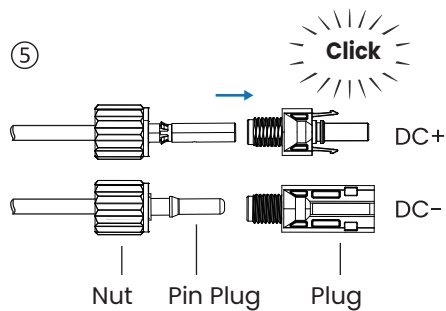

⑦

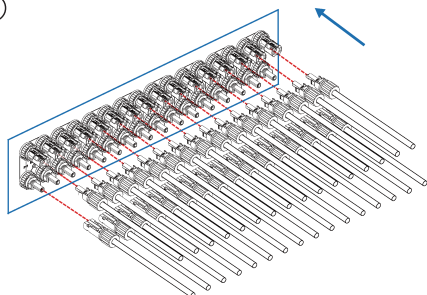

②

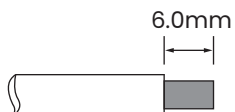

Cross-sectional area: 4-6 mm<sup>2</sup>

④

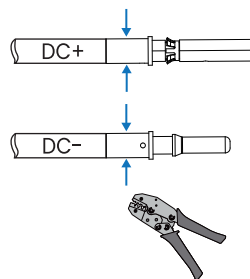

⑥

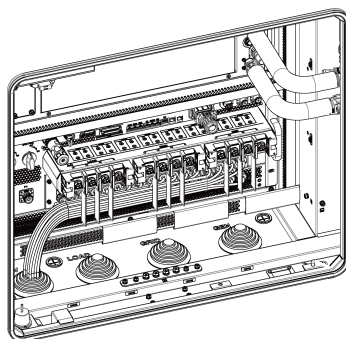
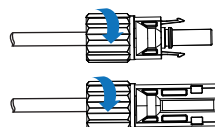

## 6.2 AC Wiring

-Recommended Specification:

Cable Type	Outer Diameter (mm)	Copper Conductor Sectional Area (mm <sup>2</sup> )
LOAD/GRID/GEN Cable	40-70	L1, L2, L3 (N) cables: 90-150 PE: S/2 (S is a sectional area of LOAD/GRID/GEN phase cable)

-Steps

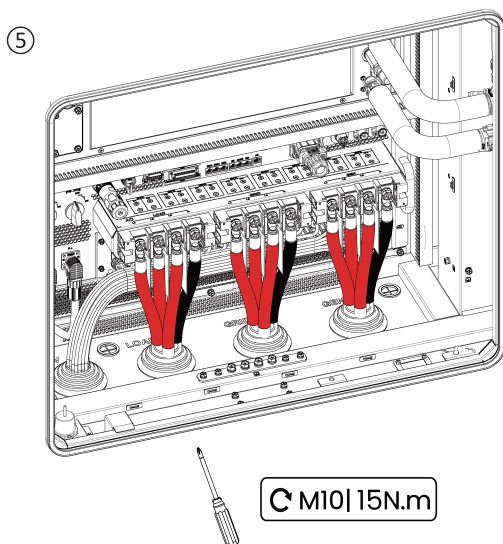

### 6.3 Ground Connection

The conductor sectional area of the ground cable is 25–50 mm<sup>2</sup> (30–35 mm<sup>2</sup> is recommended).

-Steps

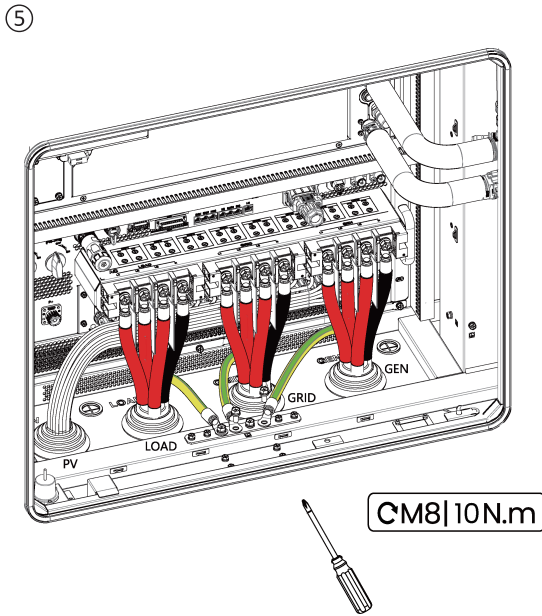
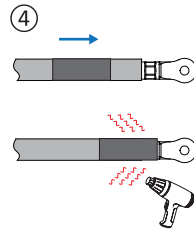
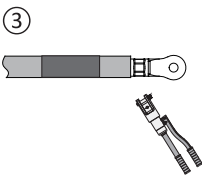
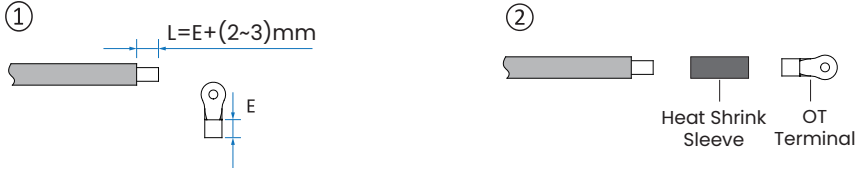

## 6.4 EPS Ground Connection

The conductor section area of the ground cable is 15-25 mm<sup>2</sup>.

-Steps

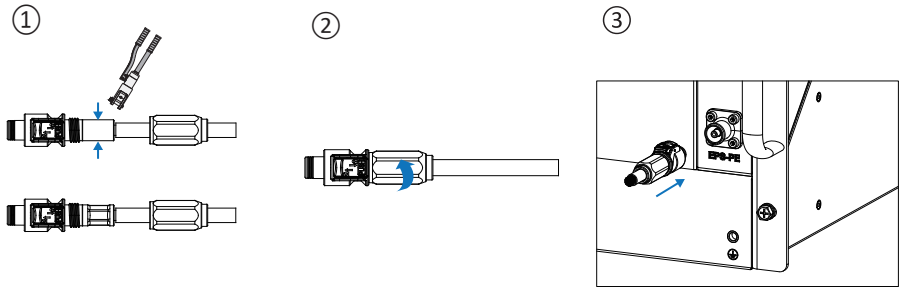

### Scenario 1

The N and PE cables need to be connected together in the service panel. For Countries such as Austrailila, New Zealand, South Africa, etc., please follow local wiring regulations.

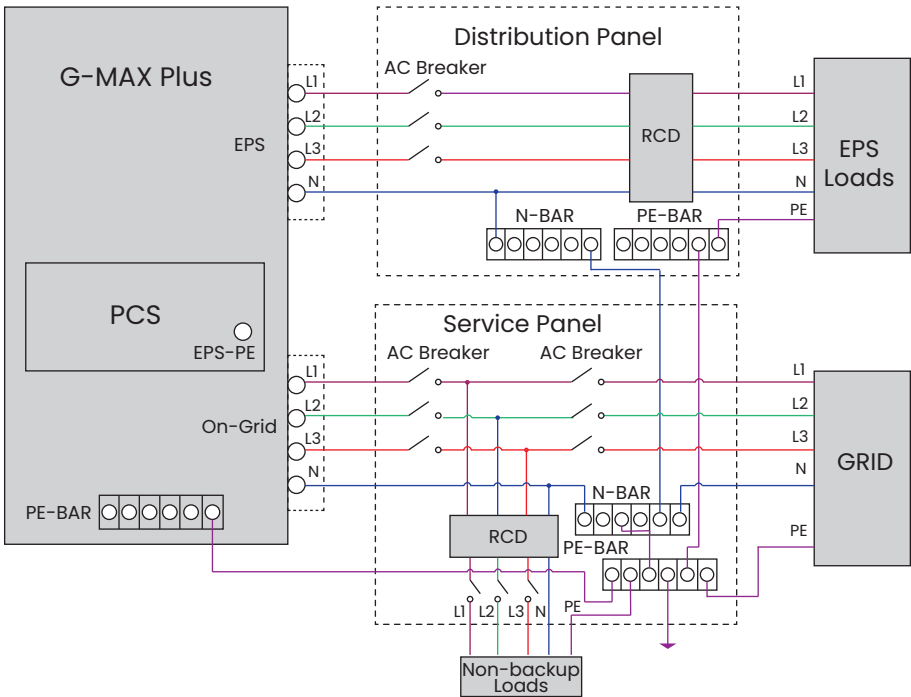

## Scenario 2

The neutral is separated from the PE in the service panel.

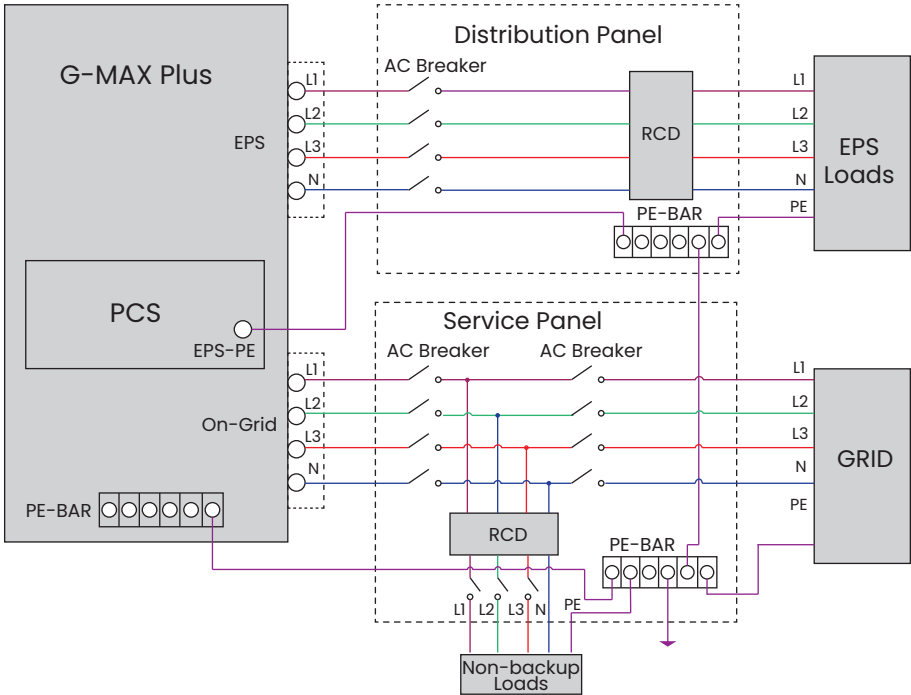

## 6.5 Meter Connection

### 6.5.1 DC Couple

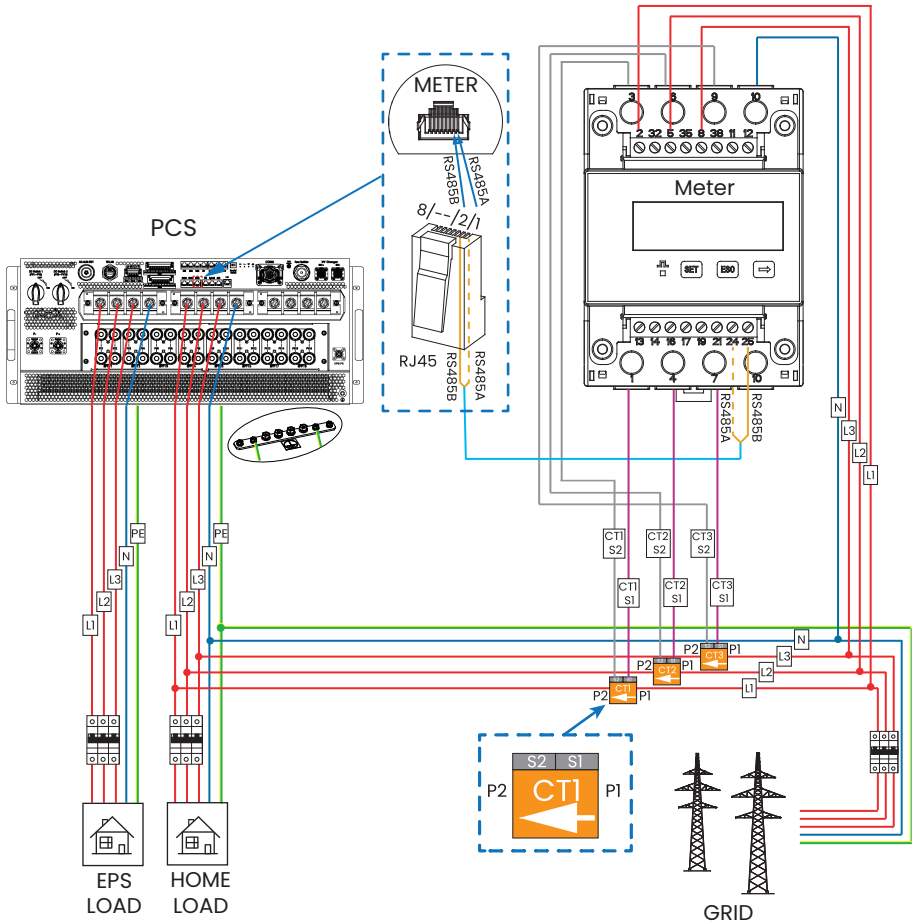

#### NOTE:



When a meter network cable is connected, RS485A and RS485B are separate communication cables and are not short-circuited with each other.

## 6.5.2 AC Couple

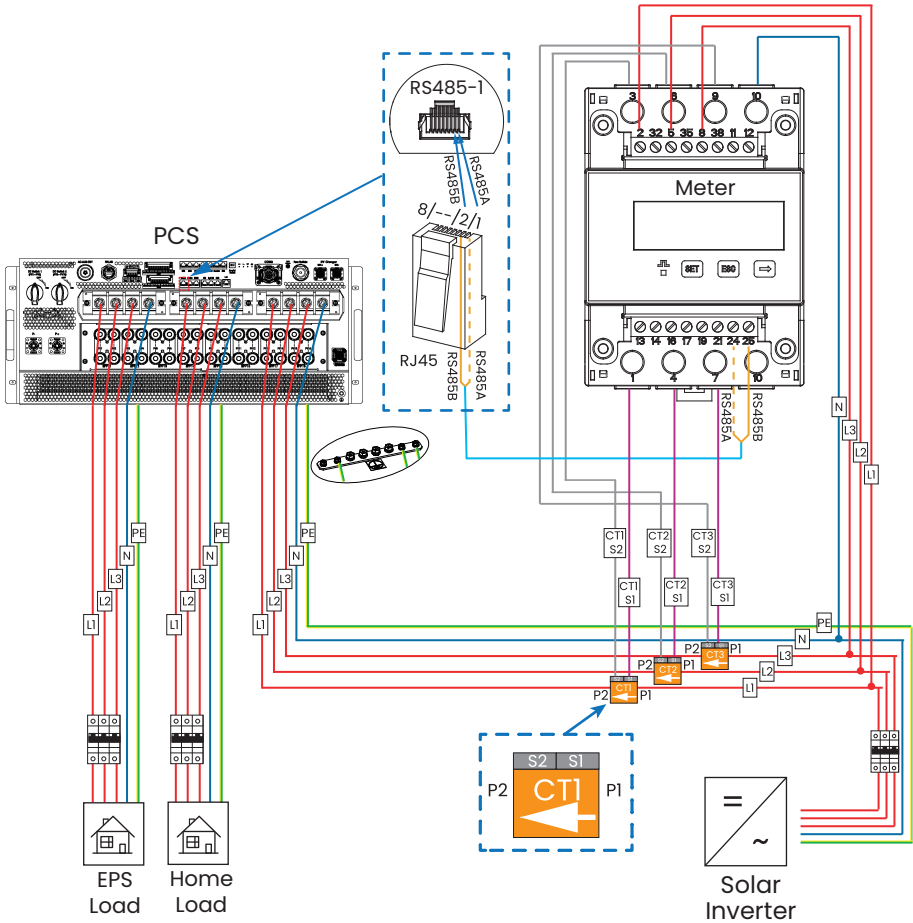

**NOTE:**



When a meter network cable is connected, RS485A and RS485B are separate communication cables and are not short-circuited with each other.

**NOTE:**

Ensure the **BAT SWITCH** is in the **OFF** state before installing the MSD.

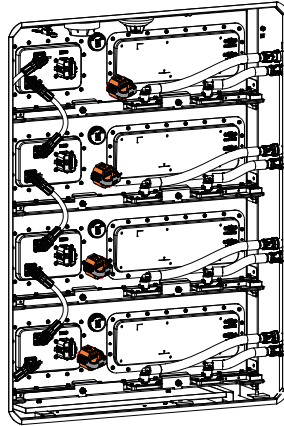
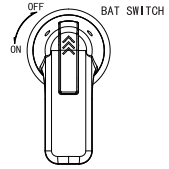
**-Steps**

- ① Plug the MSD socket into the battery.
- ② Turn the wrench to the 90-degree position.

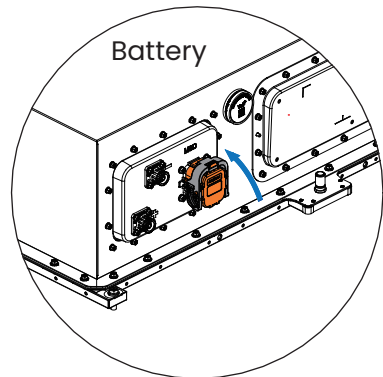
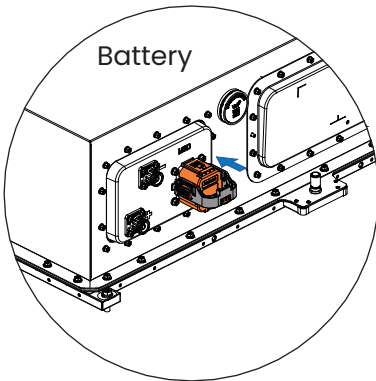

③ Push the CPA to the locking position.

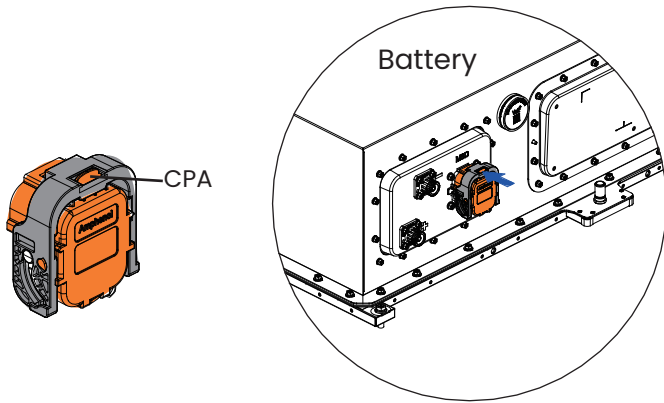

## 8 Switch Installation

### -Steps

①

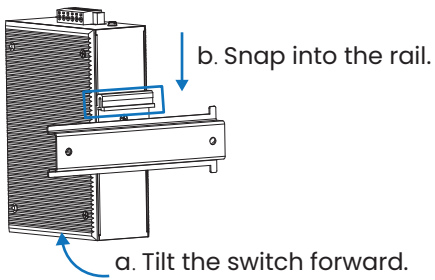

②

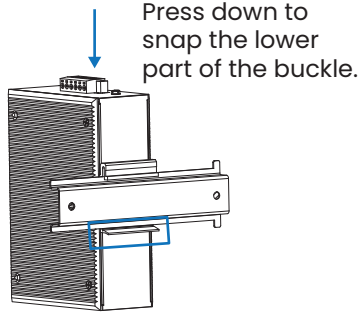

3

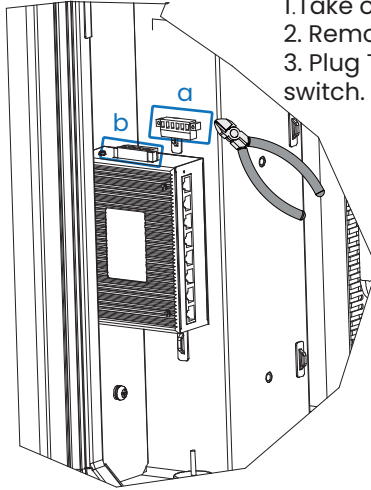
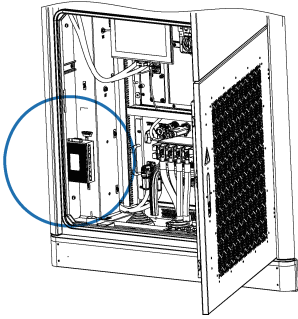

1. Take out Terminal a.
2. Remove Terminal b.
3. Plug Terminal a into the switch.

## 9 System Startup

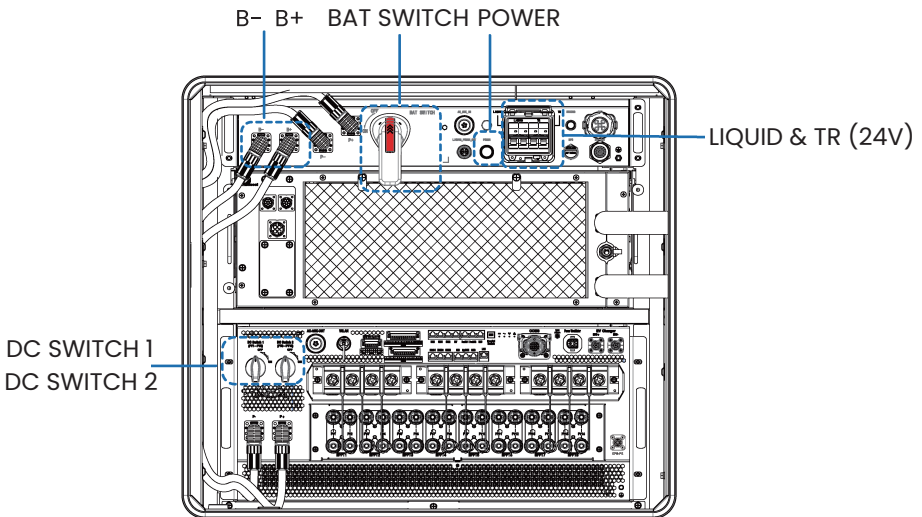

1. Turn off the **BAT SWITCH**, test the voltage of battery connectors unplugged from **B+** and **B-** with a multimeter, voltage range 672-876Vdc, and reconnect battery connectors.

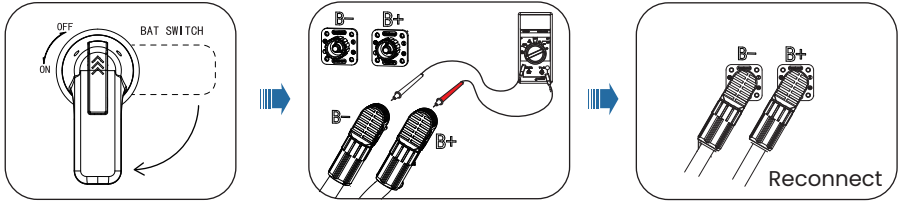

2. Turn on the **BAT SWITCH**, **LIQUID** switch, and **TR (24V)** switch.

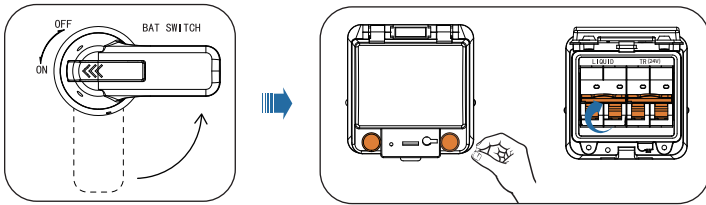

3. (Case 1) **Normal Mode**: When there is PV and grid access,

- Turn on the **DC Switches**, **AC Grid Switch** and **Load Switch**.

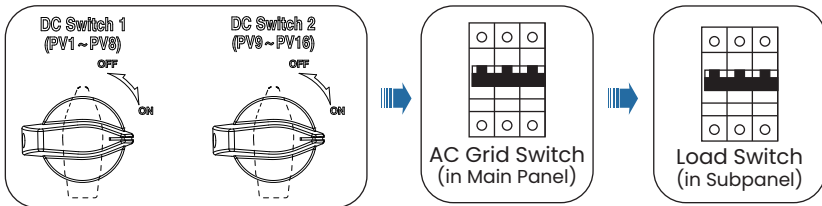

(Case 2) **Black Start**: When there is no PV and grid access,

- Press and hold the battery **POWER** button for 3 seconds, and then release.
- Press the battery **POWER** button for 3 times within 4 seconds (completed within 30 seconds of the previous step).

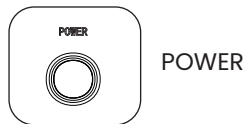

**WARNING:**

Do not turn on **DC Switches** while the unit is running. Otherwise, it may cause a system fault.

## 10 EMS Configuration

1. Enter the username “admin” and password “admin1”, and tap “Log In”. Or scan the QR code using a PAD or smartphone to connect to the device Wi-Fi and enter 192.168.138.1:8089 in the browser to access the local configuration page.

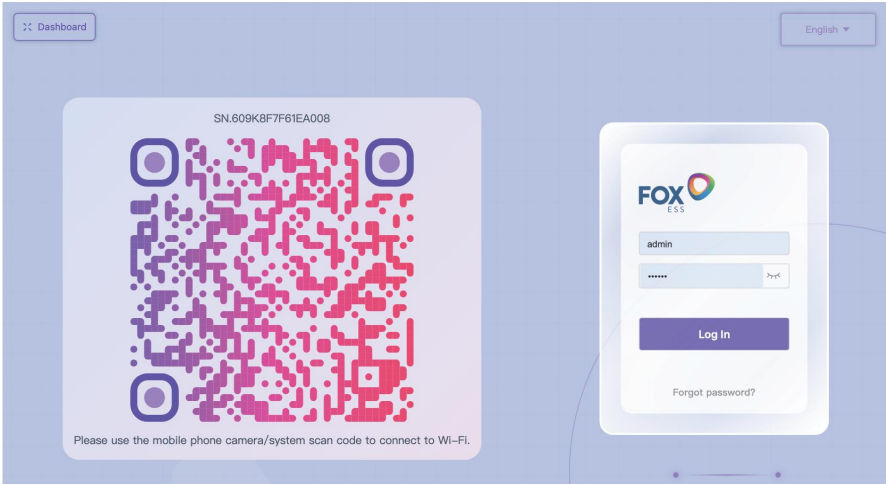

2. The default WAN mode is DHCP, allowing the device to obtain an IP address automatically from the router. For third-party EMS control, disable DHCP and configure a static IP, then tap “Submit”. After inserting the 4G SIM card, enter the data plan quota to enable data usage alerts.

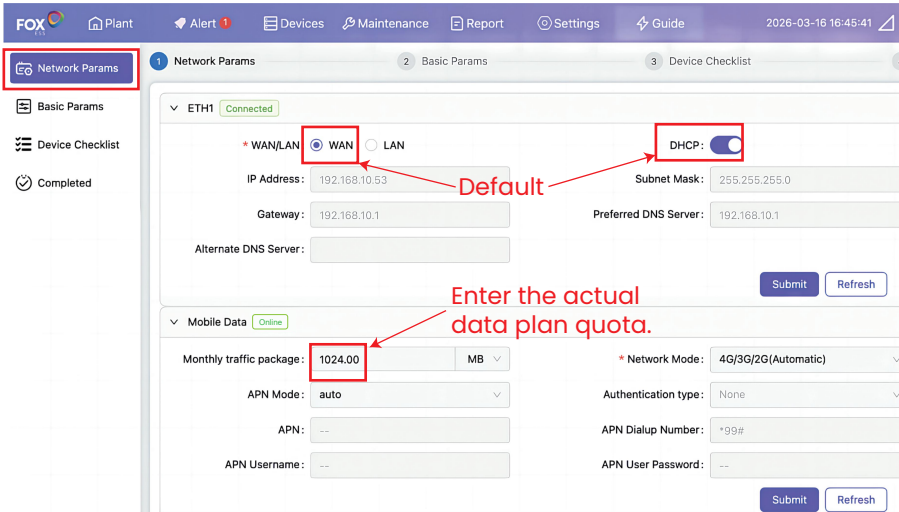

3. The default time synchronization is NTP. After connecting to the Internet, the system automatically obtains the corresponding time zone. The user can manually modify time synchronization by selecting “Manage System”, and then tap “Submit”.

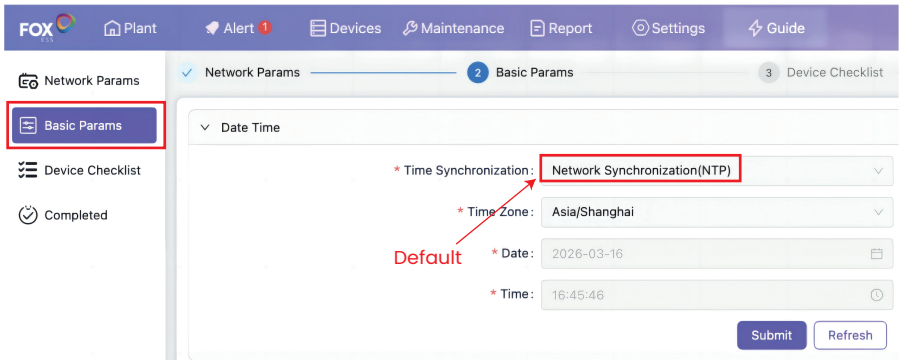

4. On Safety Settings page, select “Safety standard” as required (the latest PCS firmware version is required. If not available, disconnect the PCS AC and DC connections, then restart the PCS).

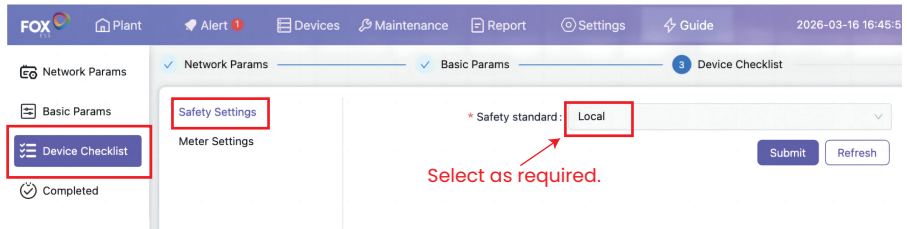

5. Select meter modes and set the CT ratio. CT ratio enable is off by default. Tap “Submit”.

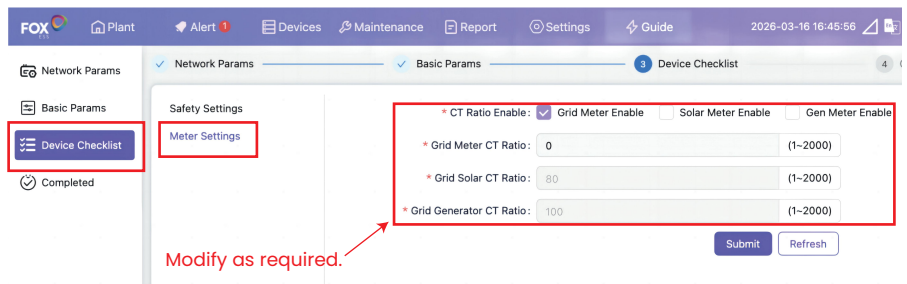

6. Check that all devices are online. Tap “Complete”. A QR code will pop up, prompting the user to login to the FoxCloud 2.0 and create a plant.

