USER MANUAL

AC EV Charger

L07P

L11P



V1.5

Table of Contents

1. Notes on This Manual	1
1.1 Scope of Validity	1
1.2 Target Group	1
1.3 Symbols Used	1
2. Safety	3
3. Packing List	4
4. Introduction	5
5. Technical Data	6
6. Installation	7
6.1 Transportation and Installation Precautions	7
6.2 Check before Installation	7
6.3 Installation	7
7. Operation	20
8. Maintenance	22
9. Decommissioning	23
9.1 Dismantling the Charger	23
9.2 Packaging	23
9.3 Storage and Transportation	23

1 Notes on This Manual

1.1 Scope of Validity

This manual describes the assembly, installation, commissioning, maintenance and troubleshooting of the following model (s) of products:

L07P
L11P

Note

Please keep this manual where it will be accessible at all times.

1.2 Target Group

This manual is for qualified electricians. The tasks described in this manual can only be performed by qualified electricians.

1.3 Symbols used

The meanings of the symbols appearing in this manual are explained below:



"Warning" indicates a hazardous situation which, if not avoided, could result in death or serious injury.







Note

"Note" provides important tips and guidance.



It means the operation on the product is correct.

Symbols on the EV Charger

Symbol	Explanation
	CE mark. Symbol explanation CE mark. The charger complies with the requirements of the applicable CE guidelines.
	Beware of hot surface. The charger can become hot during operation. Avoid contact during operation.
	Danger of high voltage. Danger to life due to the high voltage in the charger!
	UKCA mark. The charger complies with the requirements of the applicable UKCA guidelines.
	Please read the user manual carefully.
	The charger can not be disposed together with the household waste.
	RCM mark. Symbol explanation RCM mark. The charger complies with the requirements of the applicable RCM guidelines.

2 Safety

EV chargers are designed and rigorously tested in compliance with international safety standards. Nevertheless, it is imperative to adopt necessary safety precautions during the installation and operation of EV chargers. The installer is obligated to thoroughly read and adhere to all instructions, precautions, and warnings detailed in this installation manual.

- All operations encompassing transportation, installation, start-up, and maintenance must be performed by appropriately qualified and trained personnel.
- The electrical installation and maintenance of the charger should be carried out by a certified electrician in accordance with local electrical wiring codes and regulations.
- Before installation, check the unit to ensure it is free of any transport damage or handling issues.
- Unauthorized removal of necessary protective devices, improper usage, incorrect installation, or improper operation may result in serious safety hazards, shock risks, or damage to the equipment.
- Do not install the equipment in adverse environmental conditions, such as those in close proximity to flammable or explosive substances, corrosive or desert environments, areas exposed to extreme high or low temperatures, or high humidity environments.
- Do not use the equipment when the safety devices do not work or are disabled.
- During the installation process, please ensure the use of personal protective equipment, including gloves and safety goggles.
- Inform the manufacturer about non-standard installation conditions.
- Do not use the equipment in case of any operation anomalies. Avoid temporary repairs.
- All repair work must utilize only approved spare parts, which must be correctly installed according to their designed purposes by a licensed contractor or an authorized service provider.
- Liabilities stemming from commercial components shall be borne by their respective manufacturers.

3 Packing List

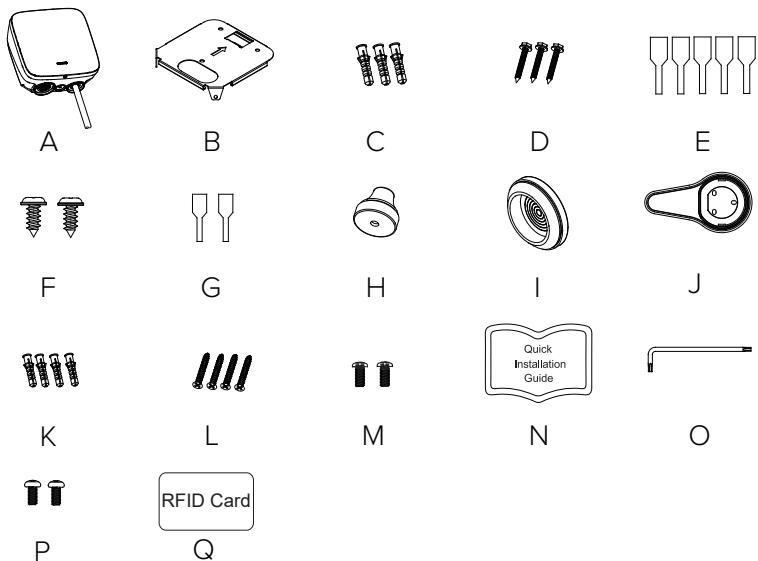

No.	Name	Quantity
A	EV Charger	1
B	Mounting backplate	1
C	Expansion pipe (Φ8*40)	3
D	Expansion screw (ST6*40)	3
E	Tubular terminal (E6012)	5
F	Self-tapping screw (ST4.2*9.5)	2
G	Tubular terminal (E0508)	2
H	Rubber curved coils (M16)	1
I	Rubber curved coils (M40)	1
J	Type 2 Plug holder	1
K	Expansion pipe (Φ6*30)	4
L	Expansion screw (ST4.2*35)	4
M	Plum head machine screw (M3*6)	2
N	Quick installation guide	1
O	Wrench (T10)	1
P	Machine screw (M3*6)	2
Q	RFID Card	2

4 Introduction

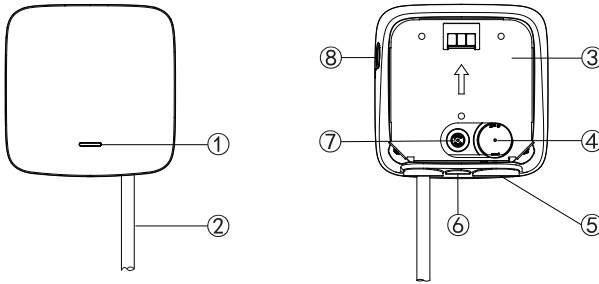

- ① Meaning of lights
 - Green breathing light -standby status
 - Blue Steady - EV Plug inserted status
 - Blue breathing light - charging start status/pause
 - Blue running light - charging status
 - Green Steady - charging end status
 - Red Steady-charger fault, shutdown protection
 - Yellow Steady - locked status
- ② EV charging cable
- ③ Mounting backplate
- ④ Back entry hole
- ⑤ Bottom entry hole
- ⑥ Bottom communication inlet hole
- ⑦ Back network inlet hole
- ⑧ Stop button

5 Technical Data

FOX ESS 7.3kW &11kW AC-CHARGER		
Model	L07P	L11P
Input		
Input line	L/N/PE	3L/N/PE
Rated voltage	230Vac, ±20%	400Vac, ±20%
Rated current	32A	16A
Rated frequency	50/60Hz	
Output		
Output voltage	230Vac, ±20%	400Vac, ±20%
Maximum output current	32A	16A
Rated power	7.3kW	11kW
Interaction method		
Connector Type	Type 2 Plug	
Start-up mode	Plug&Play/RFID card/App	
Communication method		
Bluetooth	Operating frequency range:2402~2480 MHz RF power control range:-24~20dBm	
WiFi	TX/RX frequency band:2412~2484 MHz	
OCPP	OCPP1.6 J, OCPP2.0.1	
LAN	Enable	
Environment		
Installation method	Wall mounting/floor-mounted column mounting	
Working temperature	-25°C~50°C	
Working humidity	5%~95% no condensation	
Altitude	≤2000m	
Size and weight		
Size	197*196*105 mm	
Weight	3.6kg	4.04kg
Charging Cable Length	5m (Standard), 6m(Optional)	
Safety		
Waterproof rating	IP55	
Anti-collision grade	IK08	
*RCD	6mA DC	
Protection function	Over current protection, Over/Under voltage protection, Over temperature protection,Ground protection, Surge protection	
Certification	CE/UKCA/CB/RCM	
Certification standard	EN/IEC 61851-1:2019, EN/IEC 61851-21-2:2021	

*Internal RCD-DD meets the trip time characteristics specified in IEC 62955

*External RCCB is required

*Select Type A or Type B according to local regulations.

6 Installation

6.1 Transportation and Installation Precautions

To ensure safety, attention should be given to the following points:

- All accessories should be stored separately during transportation or handling.
- Avoid exposing them to violent shocks and impacts; handle with care.
- Avoid inversion.

6.2 Check before Installation

- Unpack the EV Charger and verify the accessories against the packing list.
- Inspect the EV Charger for any damage incurred during transportation. If you find any damage or missing parts, do not power on the charger and promptly notify both the carrier and dealer.

Note

Please keep the packing boxes and packaging materials for future handling.

6.3 Installation

▪ Pre-installation preparation

The following tools are necessary for the installation process:

Phillips (crosshead) screwdriver, Special torx screwdriver, Wire strippers, Crimping pliers, Electric drill.

▪ Installation precautions

Please adhere strictly to the wiring specifications and ensure proper connection. Additionally, please confirm that all fasteners are securely tightened to safeguard the EV Charger.

▪ Installation environment and location

- The area designated for the charger must be well-ventilated and kept away from water sources, combustible gases, and corrosive agents.
- Ensure that the ground or installation platform can support the weight of the charger without issue.
- In cases where the charger is disassembled and used in low-temperature environments, condensation may occur. Prior to installation or use, ensure that the charger is completely dry to avoid the risk of electric shock.
- Position the charger near the main power input to allow installers or users to easily access and disconnect the main power switch in emergency situations, effectively cutting off the power supply

Note

The installation needs to comply with local installation requirements and safety regulations.

Before installation, ensure that the wall or column is vertical or tilted backward by 0° to 15°.

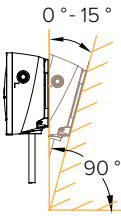

Vertical or Tilt Backward ✓

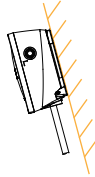

Tilt Forward ⚠️

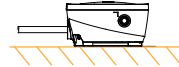

Level ⚠️

■ Wall-mounted installation method

Step 1:

On the wall, mark six holes based on the positions of the Mounting backplate and the Type 2 plug holder.

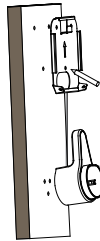

Step 2:

1. Use an 8mm drill bit to drill holes. The holes should be at least 50mm deep for mounting the Mounting backplate.
2. Use an 6mm drill bit to drill holes. The holes should be at least 40mm deep for mounting the Type 2 Plug holder.
3. Clean the area around the drilled holes.

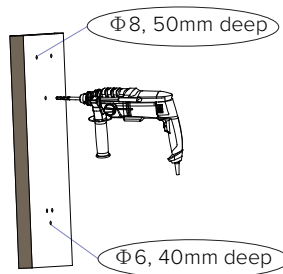

Step 3:

Insert the expansion pipe (C) and (K) into the holes and securely fasten them with a hammer.

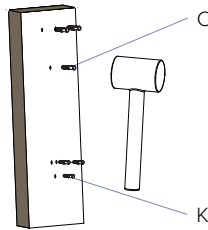

Step 4:

Affix the Mounting backplate (B) and Type 2 Plug holder (J) to the wall using screws (D) and (L).

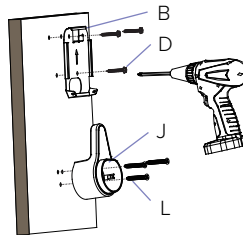

Step 5:

1. Hang the EV Charger into the Mounting backplate.
2. Remove the screws (F) and install them on the bottom of the backplate, tighten the screws.
3. Insert the charging connector into the Type 2 plug holder to complete the installation.

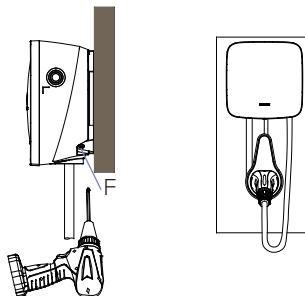

■ Floor type / Vertical installation method

Column packing list (optional):

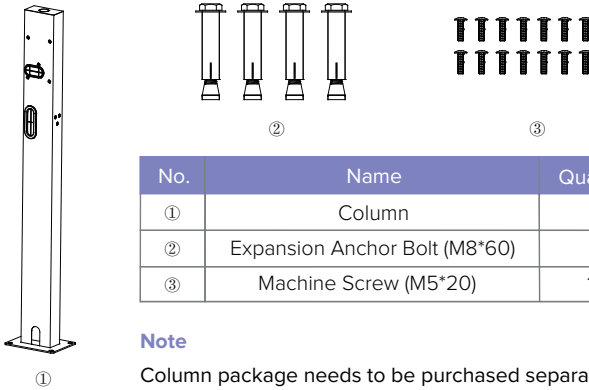

Step 1:

1. Drill four 60mm deep holes spaced 170*120mm apart using a 12mm drill bit.
2. Drill one $\Phi 60$ mm outlet hole in the center.
3. Clean the area around the drilled holes.

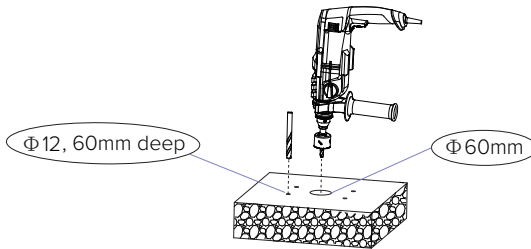

Step 2:

Install the expansion anchor bolt (2) and fix them with a wrench.

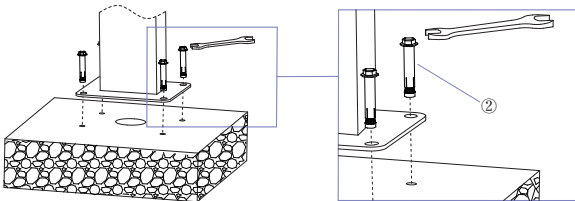

Step 3:

Route the input wire through the bottom of the column and into the hole inside.



Step 4:

Fix the Mounting backplate (B) and Type 2 Plug holder (J) to the column with screws (③).

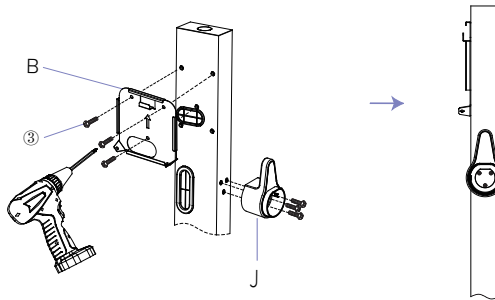

Step 5:

1. Hang the EV Charger into the Mounting backplate.
2. Remove the screws (F) and install them on the bottom of the backplate, tighten the screws.
3. Insert the charging connector into the Type 2 plug holder to complete the installation.

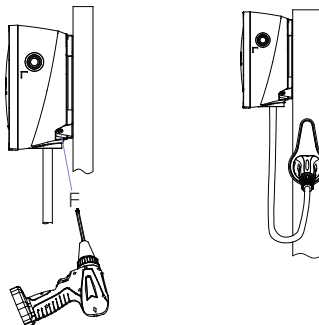

■ **Electrical Connections (from bottom)**

A leakage protection switch needs to be installed. It is recommended to use a leakage protection device of Type A, Type C40 (suitable for 7.3kW) or Type C20 (suitable for 11kW), and the input wire should be routed out from the leakage protection switch. For 7.3kW applications, a cable with a wire diameter of 6-10mm² is recommended; for 11kW applications, a 4-6mm² cable is suggested.

Trim the cable sheath to 70mm and leave the conductor exposed for 10mm.

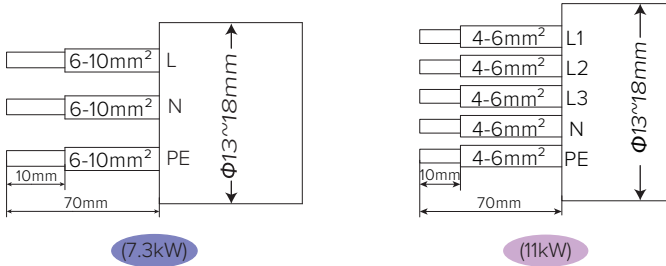

L/L1/L2/L3: Brown/red/green or yellow wire
 N:Blue/black wire PE:Yellow green wire

Note

Please refer to the local regulations on the cable model and color during installation.

Step 1:

Crimp the tubular terminal E6012 (E) onto the cable using crimping pliers.

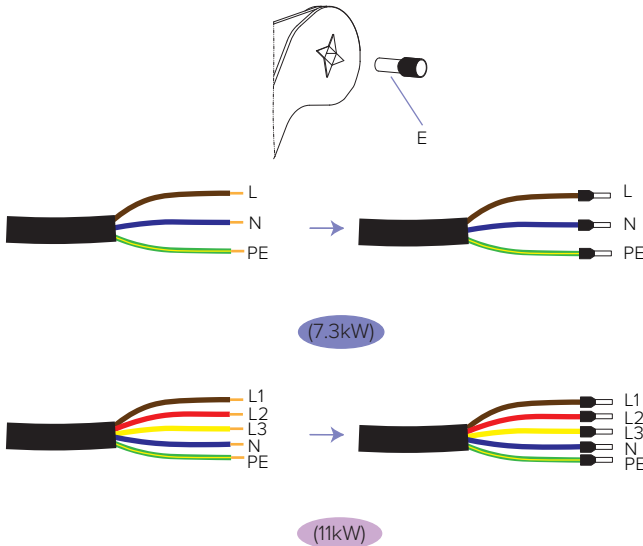

Step 2:

Use a wrench (O) to unscrew the bottom screws and remove the bottom cover.

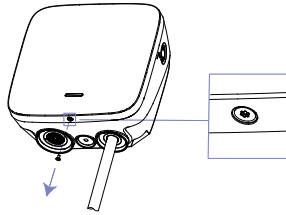

Step 3:

Unscrew the wiring cover screws and open the wiring cover.

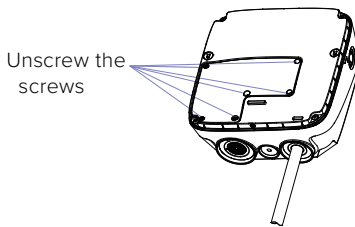

Step 4:

1. Consult the table below to determine the appropriate position of the rubber arc ring, through which you should insert either the 3-core cable (for 7.3kW) or the 5-core cable (for 11kW), based on their respective diameters.

Hole Position	A place	B place	C place	D place	E place	F place
Cable O.D.	Φ8-12mm	Φ10-18mm	Φ17-23mm	Φ21-26mm	Φ24-26mm	Φ26-28mm
Wire(mm ²)	1.5	2.5-6	10	16		

(7.3kW)

Hole Position	A place	B place	C place	D place	E place	F place
Cable O.D.	Φ8-12mm	Φ10-18mm	Φ17-23mm	Φ21-26mm	Φ24-26mm	Φ26-28mm
Wire(mm ²)		1-6	10	16		

(11kW)

2. After threading the cable through the rubber arc ring, connect the L, N, PE leads (for 7.3 kW) or the L1, L2, L3, N, PE leads (for 11 kW) to the corresponding terminals.

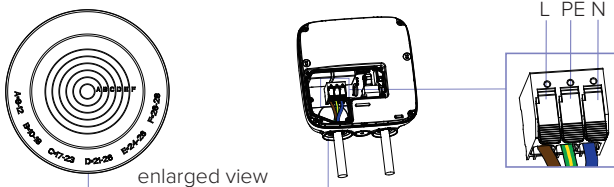

(7.3kW)

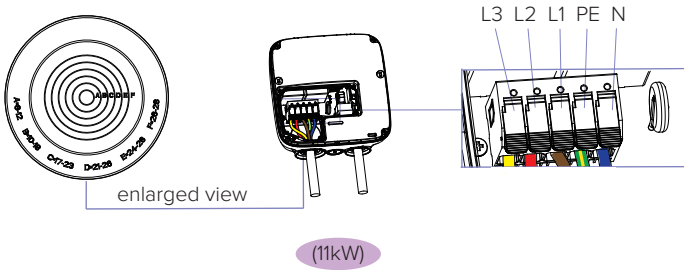

- Communication wiring connections (from bottom, when external meters need to be connected)

Step 5:

Trim all cables with a wire diameter of 0.3mm^2 to a length of 15mm (as shown in the figure), and peel off the insulation sheath to expose the conductor by approximately 8mm.



Note

Please refer to the local regulations on the cable model and color during installation.

The RS485 communication function needs to be implemented in conjunction with a meter, and the wiring diagram for the meter can be referred to in the following figure.

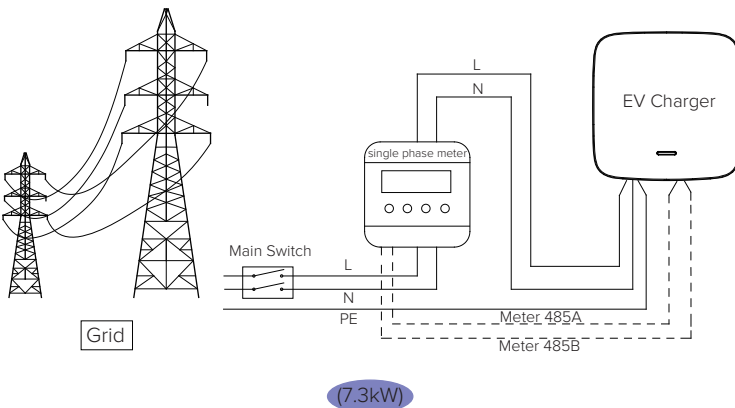

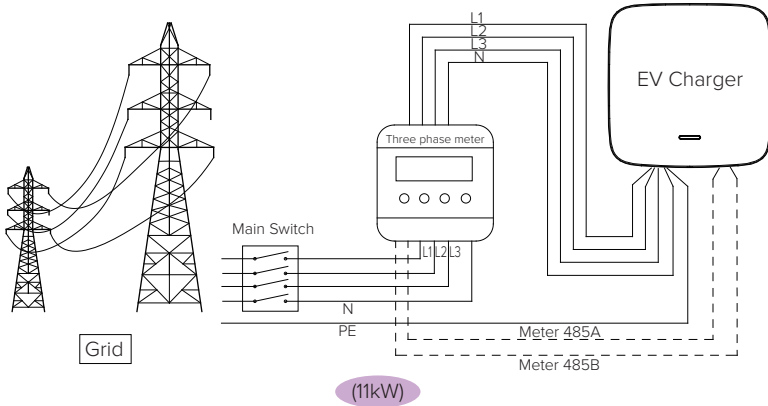

Step 6:
Crimp the tubular terminal E0508 (G) onto the cable using crimping pliers.

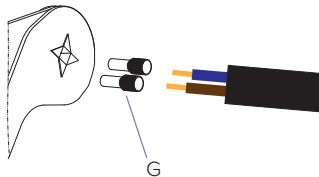

Step 7:
1. Poke the M16 rubber arc ring (H) through the center.
2. Pass the cable wires from the outside through the crossing holes.

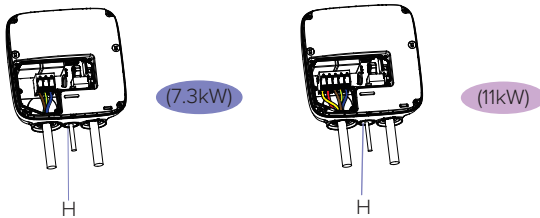

Step 8:
Install the cable into the signal terminal, then tighten the screw to compress the tubular terminal E0508.

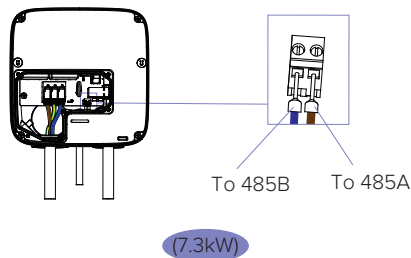

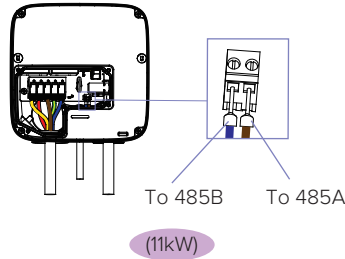

■ Network connection (optional)

The network cable interfaces of the charging pile are as follows:

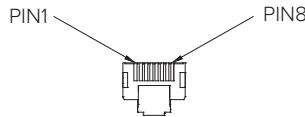

PIN	1	2	3	4	5	6	7	8
Color	White/Orange	Orange	White/Green	Blue	White/Blue	Green	White/Brown	Brown

Note

1. Ensure compliance with local regulations regarding cable type and color when installing, as the availability and performance of the network connection depend on these factors.
2. Make sure to reserve 150-160mm of network cable length on the installation surface prior to installation.

Step 9:

1. At the back of the EV Charger, process a hole with diameter $\Phi 16\text{mm}$.
2. Clean the area around the drilled holes.
3. Install the M16 rubber arc ring (H), into the hole.

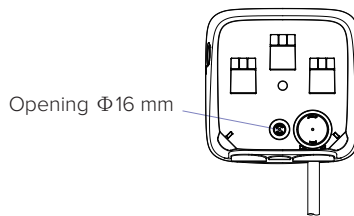

Step 10:

1. Pass the network cable through connector.
2. Strip the outer jacket of a 10mm section of the network cable using cable strippers.

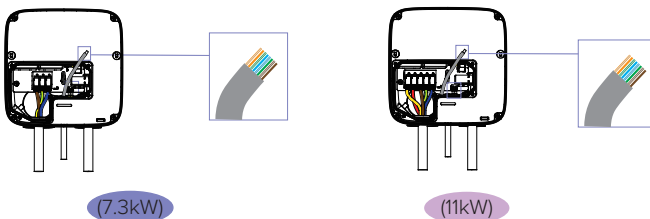

Step 11:

1. Crimp the RJ45 connector onto the network cable in the specified wiring sequence.
2. Insert the RJ45 connector with the network cable attached into the Ethernet port.

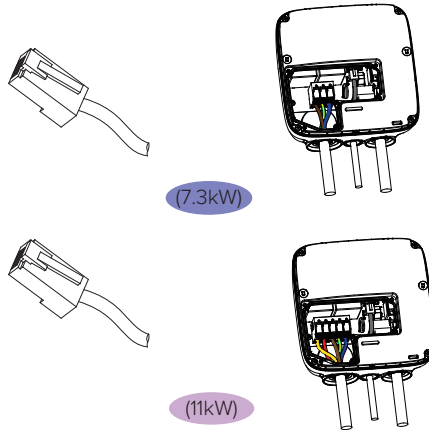

Step 12:

Check and make sure the seal is properly installed before locking the terminal cover.

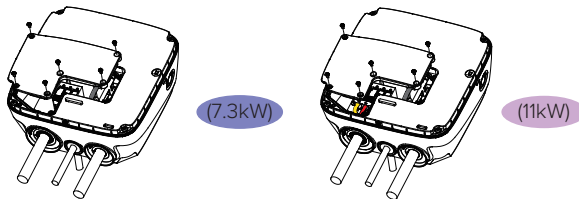

Step 13:

Put on the top cover and tighten the screws to complete the installation.

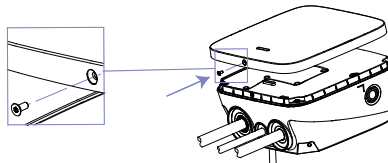

■ Electrical Connections (from back)

Complete steps 1, 2, and 3 in electrical connections (from bottom) steps first, then perform the following steps.

Step 1:

1. At the back of the EV Charger, process a hole of $\Phi 40\text{mm}$.
2. Clean the the area around the drilled holes.
3. Install the M40 rubber arc ring (I), into the hole.

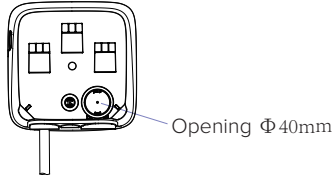

Step 2:

1. Consult the table below to determine the appropriate position of the rubber arc ring, through which you should insert either the 3-core cable (for 7.3kW) or the 5-core cable (for 11kW), based on their respective diameters.

Hole Position	A place	B place	C place	D place	E place	F place
Cable O.D.	$\Phi 8\text{-}12\text{mm}$	$\Phi 10\text{-}18\text{mm}$	$\Phi 17\text{-}23\text{mm}$	$\Phi 21\text{-}26\text{mm}$	$\Phi 24\text{-}26\text{mm}$	$\Phi 26\text{-}28\text{mm}$
Wire(mm^2)	1.5	2.5-6	10	16		

(7.3kW)

Hole Position	A place	B place	C place	D place	E place	F place
Cable O.D.	$\Phi 8\text{-}12\text{mm}$	$\Phi 10\text{-}18\text{mm}$	$\Phi 17\text{-}23\text{mm}$	$\Phi 21\text{-}26\text{mm}$	$\Phi 24\text{-}26\text{mm}$	$\Phi 26\text{-}28\text{mm}$
Wire(mm^2)		1-6	10	16		

(11kW)

2. After threading the cable through the rubber arc ring, connect the L, N, PE leads (for 7.3 kW) or the L1, L2, L3, N, PE leads (for 11 kW) to the corresponding terminals.

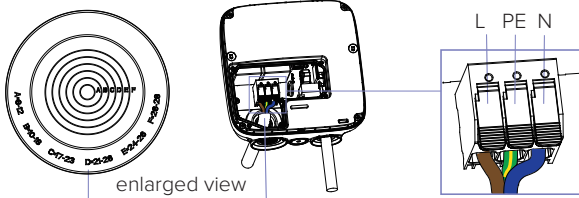

(7.3kW)

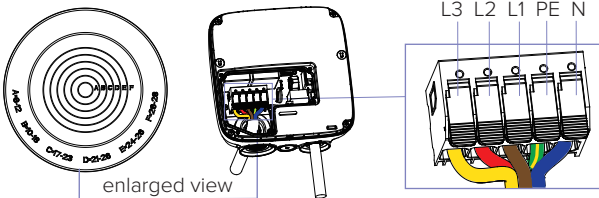

(11kW)

Note

When both communication cable and network connections are necessary, adhere to the previously described wiring steps.

Step 3:

Check and make sure the seal is properly installed before locking the terminal covers.

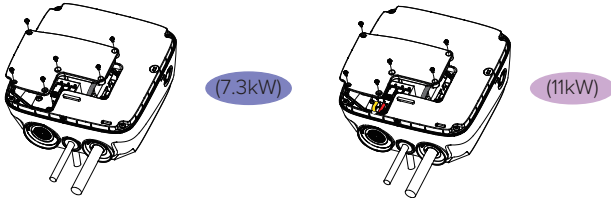
**Step 4:**

Put on the top cover and tighten the screws to complete the installation.

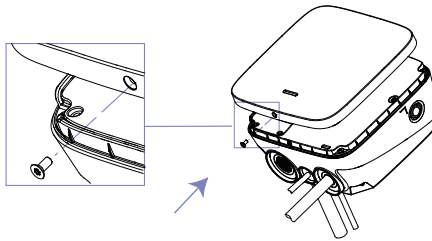

7

Operation

Charging mode and Operation

There are three charging modes which can be set on the corresponding interface of the APP: plug and charge, controlled, locked.

A. Plug and Charge mode

Charging will start automatically after EV plugged in. If you want to stop the charging, just press the stop button on the side of the charger.

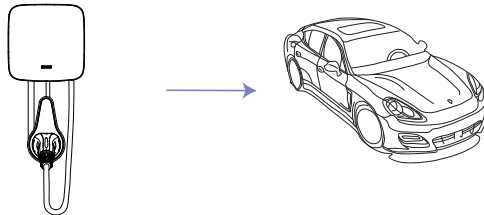

▪ Start Charging:

1. Set the charger to the plug and charge mode.
2. Insert the charging plug into the EV.
3. Charging session started.

▪ Stop Charging:

Press the stop button on the side of the charger.

B. Controlled mode

Initiate or cease charging by using APP on this mode. You can also use APP for reservations.

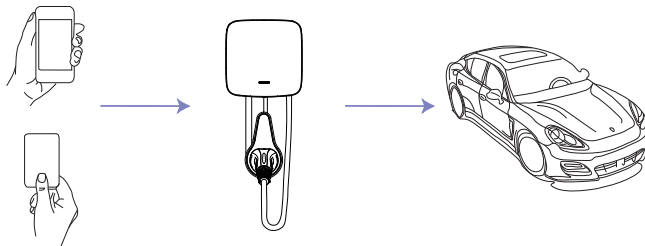

Controlled mode with RFID card

- **Start Charging:**
 1. Set the charger to the controlled mode.
 2. Insert the charging plug into the EV.
 3. Swipe card.
 4. Waiting for authorizing.
 5. Charging session started.

Controlled mode with APP

- **Start Charging:**
 1. Set the charger to the controlled mode.
 2. Insert the charging plug into the EV.
 3. Click to start the charge on the APP.
 4. Charging session started.

- **Stop Charging:**
 1. Click to stop the charge on the APP.
 2. Charging session end.

C. Locked mode

On this mode, the charger is locked and can not work.

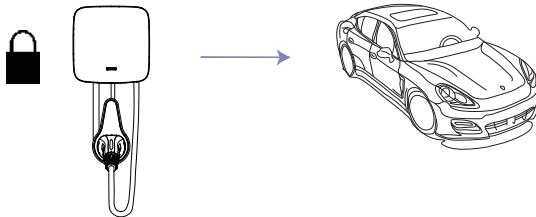

8 Maintenance

If fault occurs, users can check the fault information on the APP.

No.	Fault code on app	Solution
1	Electronic lock fault	Set the electronic lock status to the correct position. Or seek help from the installers/distributors.
2	Emergency stop fault	Reset the emergency stop button. Or seek help from the installers/distributors.
3	Abnormal CP voltage	Please inspect the EV charger thoroughly for any foreign objects or apparent damage. If no issues are detected after the inspection, please attempt to re-plug and unplug the charging gun to ascertain whether the fault is due to poor contact. Or seek help from the installers/distributors.
4	Abnormal AC output contactor	Please try to power off first and then restart the EV charger. Or seek help from the installers/distributors.
5	Over current	Please check whether the vehicle end is operating properly. Or seek help from the installers/distributors.
6	Over voltage	Wait for the grid voltage to return to normal. Or seek help from the installers/distributors.
7	Under voltage	Wait for the grid voltage to return to normal. Or seek help from the installers/distributors.
8	Electric leakage	Or seek help from the installers/distributors.
9	Reverse connection of lin N	Or seek help from the installers/distributors.
10	Abnormal frequency	Wait for the grid frequency to return to normal. Or seek help from the installers/distributors.
11	Over temperature of charging interface	Wait for the temperature of charging interface to return to normal. Or seek help from the installers/distributors.

9 Decommissioning

9.1 Dismantling the charger

- Disconnect the charger from AC input and AC output.
- Disconnect communication and optional connection wirings. Remove the charger from the bracket.
- Remove the bracket if necessary.

9.2 Packaging

If possible, please pack the charger with the original packaging. If it is no longer available, you can also use an equivalent box that meets the following requirements.

- Suitable for loads more than 30 kg.
- Contains a handle.
- Can be fully closed.

9.3 Storage and Transportation

Store the charger in a dry place where ambient temperatures are always between -40°C and +70°C. Take care of the charger during storage and transportation; keep less than 4 cartons in one stack. When the charger or other related components need to be disposed of, please ensure they are carried out according to local waste handling regulations. Please ensure that any charger that needs to be disposed of is delivered to a site approved for such disposal in accordance with local regulations.



If you need more information, please follow us on YouTube.
scan the QR code or visit
<https://www.youtube.com/@foxess5669>

Fox ESS declares that the radio equipment type LXXP is in compliance with Directive 2014/53/EU. The full text of the EU declaration of conformity is available at the following internet address: WWW.FOX-ESS.COM

Address: FOXESS CO., LTD. No. 939, Jinhai 3rd Road, Longwan District, Wenzhou, Zhejiang, China

Tel: +86(510) 68092998(General) +86(510) 68101679 (Sales)

Website: www.fox-ess.com