

---

# USER MANUAL

## 7.3kW\*2&11kW\*2&22kW\*2 AC EV Charger

C014KS2-E-1  
C022KS2-E-1  
C044KS2-E-1

C014KS2-T2S-1  
C022KS2-T2S-1  
C044KS2-T2S-1

C014KP2-E-1  
C022KP2-E-1  
C044KP2-E-1

## 7.3kW&11kW&22kW AC EV Charger

C007KS1-E-1  
C011KS1-E-1  
C022KS1-E-1

C007KS1-T2S-1  
C011KS1-T2S-1  
C022KS1-T2S-1

C007KP1-E-1  
C011KP1-E-1  
C022KP1-E-1



# Table of Contents

|                                     |           |
|-------------------------------------|-----------|
| <b>1. Notes on This Manual</b>      | <b>1</b>  |
| 1.1 Scope of Validity               | 1         |
| 1.2 Target Group                    | 1         |
| 1.3 Symbols Used                    | 1         |
| <b>2. Safety</b>                    | <b>3</b>  |
| <b>3. Packing List</b>              | <b>4</b>  |
| <b>4. Introduction</b>              | <b>5</b>  |
| <b>5. Technical Data</b>            | <b>6</b>  |
| <b>6. Installation</b>              | <b>8</b>  |
| 6.1 Loading & Unloading of Products | 8         |
| 6.2 Check before Installation       | 8         |
| 6.3 Installation                    | 8         |
| <b>7. Operation</b>                 | <b>39</b> |
| 7.1 Charging mode and Operation     | 39        |
| 7.2 Display Descriptions            | 41        |
| <b>8. Maintenance</b>               | <b>45</b> |
| <b>9. Decommissioning</b>           | <b>46</b> |
| 9.1 Dismantling the Charger         | 46        |
| 9.2 Packaging                       | 46        |
| 9.3 Storage and Transportation      | 46        |
| 9.4 Network Port Exposure Statement | 46        |

# 1 Notes on this Manual

## 1.1 Scope of Validity

This manual describes the assembly, installation, commissioning, maintenance and troubleshooting of the following model (s) of products:

---

**C014KS2-E-1**

---

**C014KS2-T2S-1**

---

**C014KP2-E-1**

---

**C022KS2-E-1**

---

**C022KS2-T2S-1**

---

**C022KP2-E-1**

---

**C044KS2-E-1**

---

**C044KS2-T2S-1**

---

**C044KP2-E-1**

---

**C007KS1-E-1**

---

**C007KS1-T2S-1**

---

**C007KP1-E-1**

---

**C011KS1-E-1**

---

**C011KS1-T2S-1**

---

**C011KP1-E-1**

---

**C022KS1-E-1**

---

**C022KS1-T2S-1**

---

**C022KP1-E-1**

---

## 1.2 Target Group

This manual is for qualified electricians. The tasks described in this manual can only be performed by qualified electricians.

## 1.3 Symbols used

The meanings of the symbols appearing in this manual are explained below:



"Warning" indicates a hazardous situation which, if not avoided, could result in death or serious injury.

---

**Note**







"Note" provides important tips and guidance.



It means the operation on the product is correct.

---

## Symbols on the EV Charger

| Symbol  | Explanation  |
|---|--|
|  | CE mark.<br>The charger complies with the requirements of the applicable CE guidelines.                |
|  | Beware of hot surface.<br>The charger can become hot during operation. Avoid contact during operation. |
|  | Danger of high voltage.<br>Danger to life due to the high voltage in the charger!                      |
|  | UKCA mark.<br>The charger complies with the requirements of the applicable UKCA guidelines.            |
|  | RCM mark.<br>The charger complies with the requirements of the applicable RCM guidelines.              |
|  | Please read the user manual carefully.   |
|  | The charger can not be disposed together with the household waste.                                     |

## 2 Safety

EV Charger are designed and tested in accordance with international safety requirements. However, certain safety precautions must be taken when installing and operating this. The installer must read and follow all instructions, cautions and warnings in this installation manual.

- All operations including transport, installation, start-up and maintenance, must be carried out by qualified, trained personnel.
- The electrical installation & maintenance of the charger shall be conducted by a licensed electrician and shall comply with local wiring rules and regulations.
- Before installation, check the unit to ensure it is free of any transport or handling.
- Unauthorized removal of necessary protections, improper use, incorrect installation and operation may lead to serious safety and shock hazards or equipment damage.
- Do not install the equipment in adverse environmental conditions such as in close proximity to flammable or explosive substances; in a corrosive or desert environment; where there is exposure to extreme high or low temperatures; or where humidity is high.
- Do not use the equipment when the safety devices do not work or are disabled.
- Use personal protective equipment, including gloves and safety goggles during the installation.
- Inform the manufacturer about non-standard installation conditions.
- Do not use the equipment in case of any operation anomalies. Avoid temporary repairs.
- All repairs should be carried out using only approved spare parts, which must be installed in accordance with their intended use and by a licensed contractor or authorized service partner.
- Liabilities arising from commercial components are delegated to their respective manufacturers.

### 3 Packing List

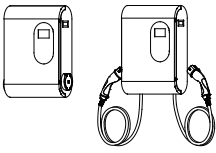

A

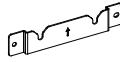

B



C



D



E



F



G



H



I



J



K

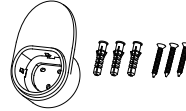

L

| No. | Name                                       | Quantity |
|-----|--|----------|
| A   | EV Charger (Plug or Socket Version)        | 1        |
| B   | Mounting Backplate                         | 1        |
| C   | RFID Card                                  | 2        |
| D   | Socket Head Cap Screw (ST5*11)             | 2        |
| E   | Expansion Pipe (Φ8*40)                     | 3        |
| F   | Expansion Screw (ST6*40)                   | 3        |
| G   | Tubular Terminal (EVN16-12)                | 6        |
| H   | Tubular Terminal (EVN10-12)                | 6        |
| I   | Tubular Terminal (EVN6012)                 | 6        |
| J   | Tubular Terminal (EVN7510)                 | 10       |
| K   | Torx-TR 20 Electric Screwdriver Bit        | 1        |
| L   | Type 2 Plug Holder and Fixing Screws(Plug) | 2        |

## 4 Introduction

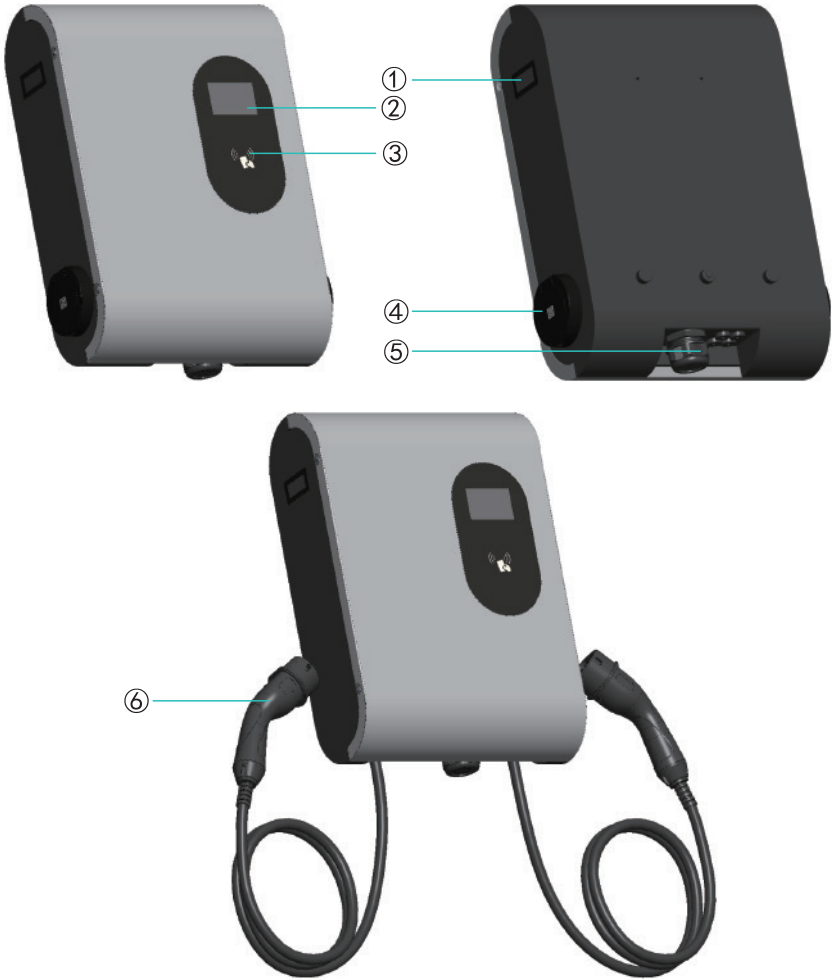

- ① Meter windows
- ② Display screen
- ③ Swipe zone
- ④ Socket
- ⑤ Lower side access to wiring area
- ⑥ Plug

## 5 Technical Data

| FOX-ESS 7.3kW*2&11kW*2&22kW*2 AC-CHARGER SPEC |  |             |                              |             |                              |             |
|---|--|-------------|------------------------------|-------------|------------------------------|-------------|
| Model   | C014KS2-E-1<br>C014KS2-T2S-1   | C014KP2-E-1 | C022KS2-E-1<br>C022KS2-T2S-1 | C022KP2-E-1 | C044KS2-E-1<br>C044KS2-T2S-1 | C044KP2-E-1 |
| <b>Input</b>                                  |  |             |                              |             |                              |             |
| Wiring Scheme                                 | L/N/PE   |             | 3L/N/PE                      |             |                              |             |
| Rated voltage                                 | 230Vac, ±20%   |             | 400Vac, ±20%                 |             |                              |             |
| Rated current                                 | 32A*2  |             | 16A*2                        |             | 32A*2                        |             |
| Rated frequency                               | 50/60Hz  |             |                              |             |                              |             |
| Standby Power Consumption                     | ≤10W   |             |                              |             |                              |             |
| <b>Output</b>                                 |  |             |                              |             |                              |             |
| Output voltage                                | 230Vac, ±20%   |             | 400Vac, ±20%                 |             |                              |             |
| Maximum output current                        | 32A*2  |             | 16A*2                        |             | 32A*2                        |             |
| Rated power                                   | 7.3kW*2  |             | 11kW*2                       |             | 22kW*2                       |             |
| Power Accuracy                                | ≤1%  |             |                              |             |                              |             |
| <b>Interaction method</b>                     |  |             |                              |             |                              |             |
| Connector Type                                | IEC 62196 Type 2 Cable, Type 2 Socket, Type 2 Socket With Shutter  |             |                              |             |                              |             |
| Integrated charging cable                     | Not present  | 5 m         | Not present                  | 5 m         | Not present                  | 5 m         |
| Metering                                      | MID Certified  |             |                              |             |                              |             |
| HMI   | 3.5 inch, IPS-TFT LCD  |             |                              |             |                              |             |
| Start-up mode                                 | APP / RFID Card / Plug&charge  |             |                              |             |                              |             |
| <b>Communication method</b>                   |  |             |                              |             |                              |             |
| RFID  | Operating Frequency Band: 13.56MHz<br>Maximum output power: 6.32dBμA/m@3m ;<br>57.82dBμV/m@3m  |             |                              |             |                              |             |
| Bluetooth                                     | Operating Frequency Band: 2402-2480MHz (TX/RX)<br>Maximum output power: 8.68 dBm   |             |                              |             |                              |             |
| WiFi (2.4GHz)                                 | Operating Frequency Band: 2412-2472MHz (TX/RX)<br>Maximum output power: 19.99 dBm  |             |                              |             |                              |             |
| 4G LTE  | Operating Frequency Band:<br>GSM 900: 880-915MHz (Uplink), 925-960MHz (Downlink)<br>DCS 1800: 1710-1785MHz (Uplink), 1805-1880MHz (Downlink)<br>LTE Band 1: 1920-1980MHz (Uplink), 2110-2170MHz (Downlink)<br>LTE Band 3: 1710-1785MHz (Uplink), 1805-1880MHz (Downlink)<br>LTE Band 7: 2500-2570MHz (Uplink), 2620-2690MHz (Downlink)<br>LTE Band 8: 880-915MHz (Uplink), 925-960MHz (Downlink)<br>LTE Band 20: 832-862MHz (Uplink), 791-821MHz (Downlink)<br>LTE Band 28: 703-748 MHz (Uplink), 758-803 MHz (Downlink)<br>LTE Band 38: 2570-2620 MHz (Uplink), 2570-2620 MHz (Downlink)<br>LTE Band 40: 2300-2400 MHz (Uplink), 2300-2400 MHz (Downlink)<br>Maximum output power:<br>GSM: ≤35dBm (GSM 900); ≤32dBm (GSM 1800)<br>LTE: ≤25dBm |             |                              |             |                              |             |
| Ethernet (RJ45)                               | Yes  |             |                              |             |                              |             |
| Communication with the vehicle                | ISO 15118 hardware ready   |             |                              |             |                              |             |
| OCPP  | 1.6J or 2.0.1  |             |                              |             |                              |             |
| Payment Mode                                  | QR Code, Cloud Payment (No Built-in POS)   |             |                              |             |                              |             |

| FOX-ESS 7.3kW*2&11kW*2&22kW*2 AC-CHARGER SPEC |   |             |                              |             |                              |             |
|---|---|-------------|------------------------------|-------------|------------------------------|-------------|
| Model   | C014KS2-E-1<br>C014KS2-T2S-1  | C014KP2-E-1 | C022KS2-E-1<br>C022KS2-T2S-1 | C022KP2-E-1 | C044KS2-E-1<br>C044KS2-T2S-1 | C044KP2-E-1 |
| <b>Environment</b>                            |   |             |                              |             |                              |             |
| Installation method                           | Wall mounting   |             |                              |             |                              |             |
| Working temperature                           | -25°C~50°C  |             |                              |             |                              |             |
| Working humidity                              | 5%-95% no condensation  |             |                              |             |                              |             |
| Altitude                                      | ≤2000m  |             |                              |             |                              |             |
| <b>Size and weight</b>                        |   |             |                              |             |                              |             |
| Size  | 526.5*407*150 mm (Socket) , 526.5*365*150 mm(Plug)  |             |                              |             |                              |             |
| Weight  | ≤11.5kg (Socket) , ≤16.5kg(Plug)  |             |                              |             |                              |             |
| <b>Safety</b>                                 |   |             |                              |             |                              |             |
| Waterproof rating                             | IP55  |             |                              |             |                              |             |
| Anti-collision grade                          | IK10  |             |                              |             |                              |             |
| Residual Current Detection                    | Built-in Type A 30 mA + DC 6mA  |             |                              |             |                              |             |
| Electrical Protection                         | Over/Under Voltage Protection,<br>Overcurrent Protection,<br>Leakage Current,<br>Ground Protection,<br>Surge Protection,<br>Overtemperature Protection,<br>Tamper Protection, PEN |             |                              |             |                              |             |
| Environmental Protection                      | Salt-mist-resistant, UV-resistant Treatment   |             |                              |             |                              |             |
| Certification                                 | CE / UKCA / CB / RCM  |             |                              |             |                              |             |
| Certification standard                        | EN/IEC 61851-1: 2019, EN/IEC 61851-21-2: 2021   |             |                              |             |                              |             |

# 6 Installation

## 6.1 Loading & Unloading of Products

To ensure safety, the following points should be paid attention to:

- All accessories are placed separately during transportation or handling.
- Avoid violent shock and impact, and take it lightly.
- Avoid inversion.

## 6.2 Check before Installation

- Open the EV Charger packaging, and check the accessories according to the packing list.
- Check whether the EV Charger is damaged during transportation. If there is any damage or missing parts, do not boot up the EV charger and inform the carrier and dealer immediately. Determine if this EV charger is the model that you want to purchase.

### Note

Please keep the packing boxes and packaging materials for future handling.

## 6.3 Installation

### ■ Pre-installation preparation

The following tools are required for the installation:

Cross screwdriver, special plum screwdriver, stripping pliers, pressing pliers.

### ■ Installation precautions

Please strictly follow the wiring requirements and correct access.

Please confirm that all fasteners are locked to secure the EV Charger.

### ■ Installation environment and location

- The area where the charger will be placed must be well ventilated, far away from water, combustible gas and corrosive agent.
- Ensure that the ground or installation platform can withstand the weight of the charger.
- If the charger is disassembled and used in the low temperature environment, water droplets condensation phenomenon may occur. Ensure that the charger is thoroughly dry before installation or use, avoiding the danger of electric shock.
- Please place the charger near the mains input so that installers or users can disconnect the mains input switch and cut off the power supply timely in case of emergency.

### Note

The installation needs to comply with local installation requirements and safety regulations.

Ensure that the wall or column is vertical or tilted 15 ° backward before installation.

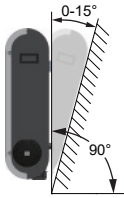

Tilt Backward ✓



Tilt Forward ⚠  
WARNING

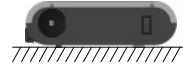

Level ⚠  
WARNING

### Wall-mounted installation method

Step 1:

Mark 3 holes according to the installation positioning card on the wall.

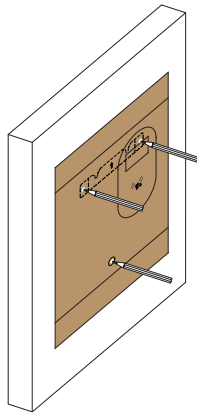

Step 2:

1. Use an  $\Phi 8$ mm drill bit to drill holes. The holes should be at least 50mm deep.
2. Insert the expansion pipe (E) into the hole and fix it tightly with a hammer.

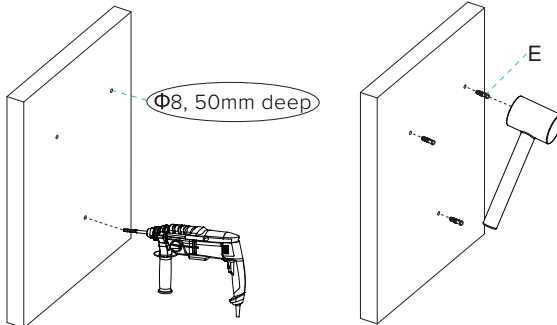

## Step 3:

Fix the Mounting backplate (B) to the wall with screws (F).

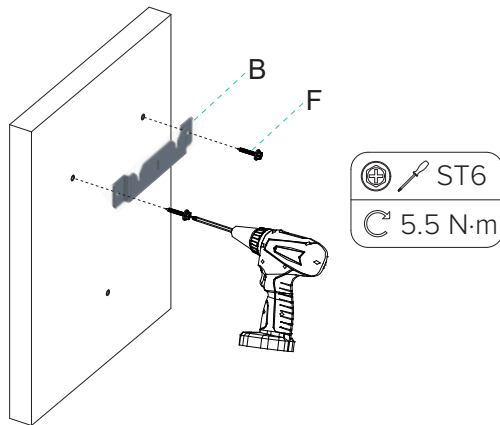

## Step 4:

1. Secure the Socket Head Cap Screw (D) to the EV Charger.
2. Remove the stopper on the back.

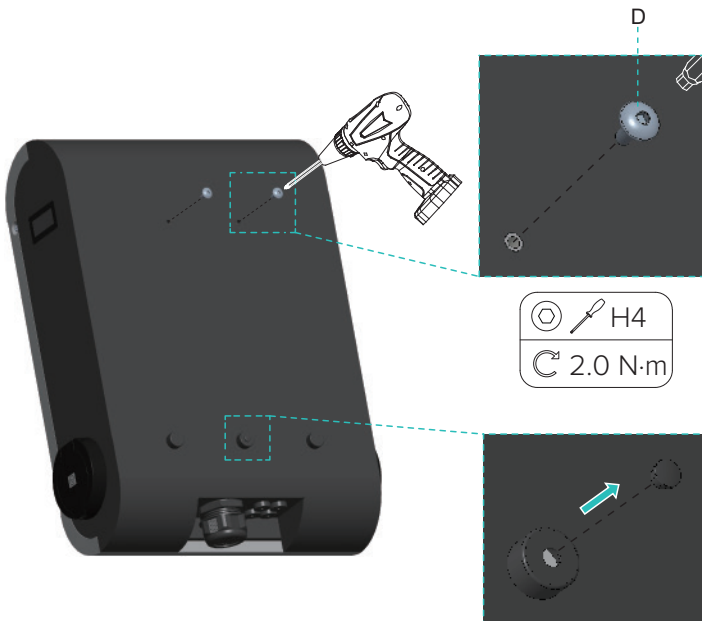

## Step 5:

Using the Torx-TR 20 Electric Screwdriver Bit (K) , remove the four screws on both sides.

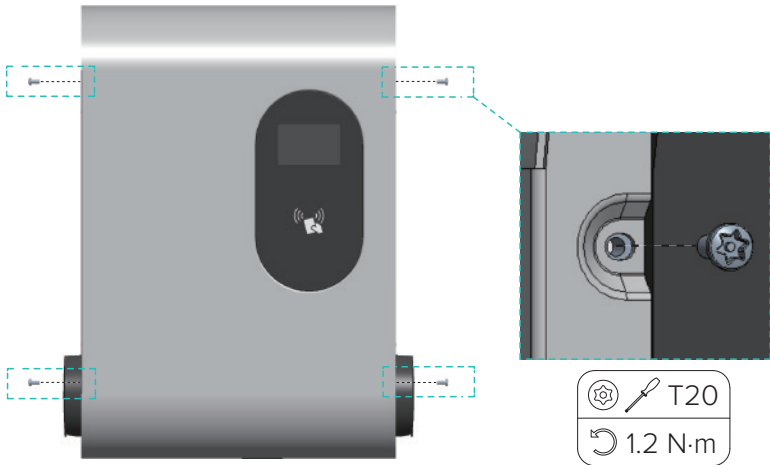

## Step 6:

First lift the lower edge of the top cover, then remove the top cover by pulling it upward.



Step 7:

1. Hook the EV Charger to the Mounting Backplate (B).
2. Fix the Expansion Screw (F). Installation complete.

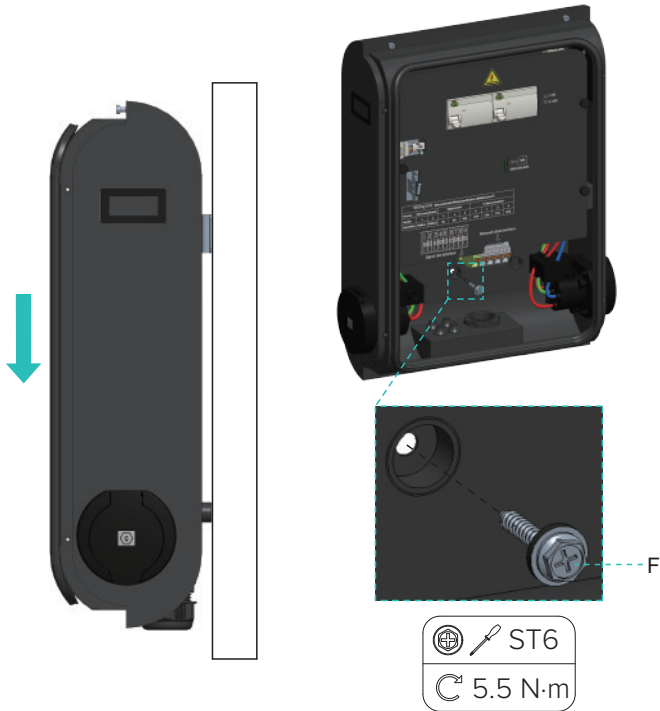

Floor type / Vertical installation method

Column packing list:

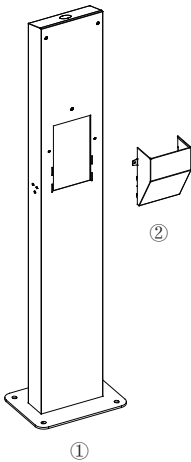

| S/N | Name                                | Quantity |
|-----|-------------------------------------|----------|
| ①   | Installation column                 | 1        |
| ②   | Cable Protective Cover              | 1        |
| ③   | Expansion Anchor Bolt (M8*60)       | 4        |
| ④   | Screws Hex Head with Washer (M6*20) | 3        |
| ⑤   | Torx-TR 20 Security Screw (M4*12)   | 8        |

**Note**

Column products need to be purchased additionally.

Step 1:

1. Drill four 60 mm deep holes spaced 260\*180 mm apart using a  $\Phi 12$  mm drill bit.
2. Drill one  $\Phi 60$ mm outlet hole in the center.
3. Clean the hole position.

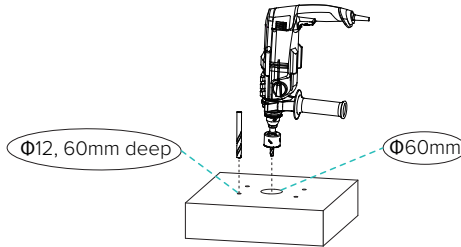

Step 2:

Align the four mounting holes at the base of the Installation column, route power cables and signal cables upward to the front opening.

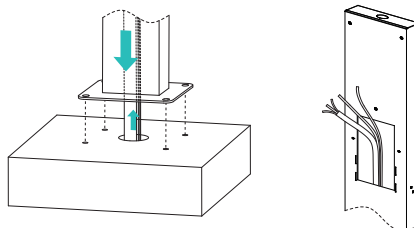

Step 3:

Install the expansion anchor bolt (③) and fix them with a wrench.

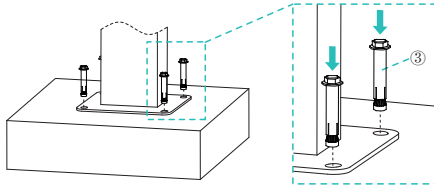

Step 4

Fix the Mounting backplate (B) to the Installation column with Screws Hex Head with Washer (④).

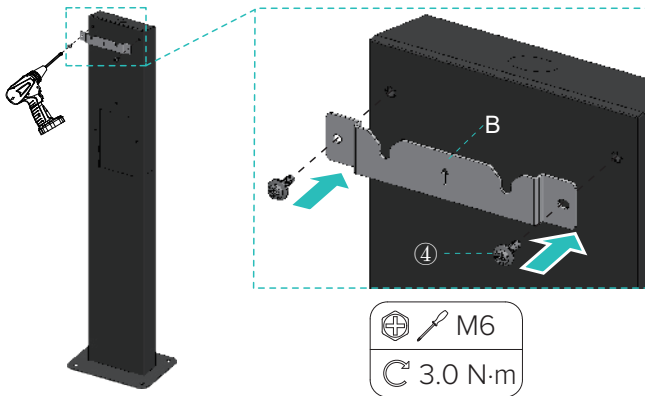

Step 5:

1. Secure the Socket Head Cap Screw (D) to the EV Charger.
2. Remove the stopper on the back.

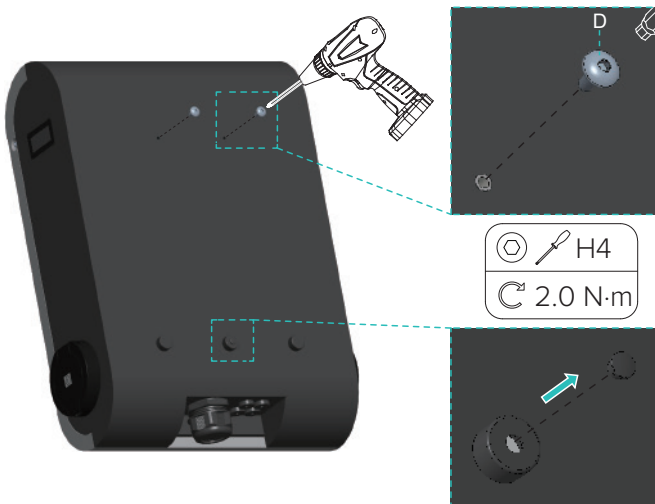

## Step 6:

Using the Torx-TR 20 Electric Screwdriver Bit (K) , remove the four screws on both sides.

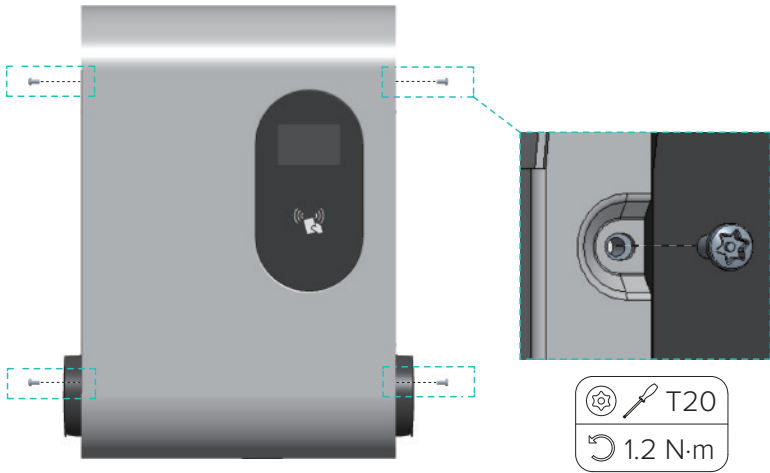

## Step 7:

First lift the lower edge of the top cover, then remove the top cover by pulling it upward.



Step 8:

1. Hook the EV Charger to the Mounting Backplate (B).
2. Fix the Screws Hex Head with Washer (④). Installation complete.

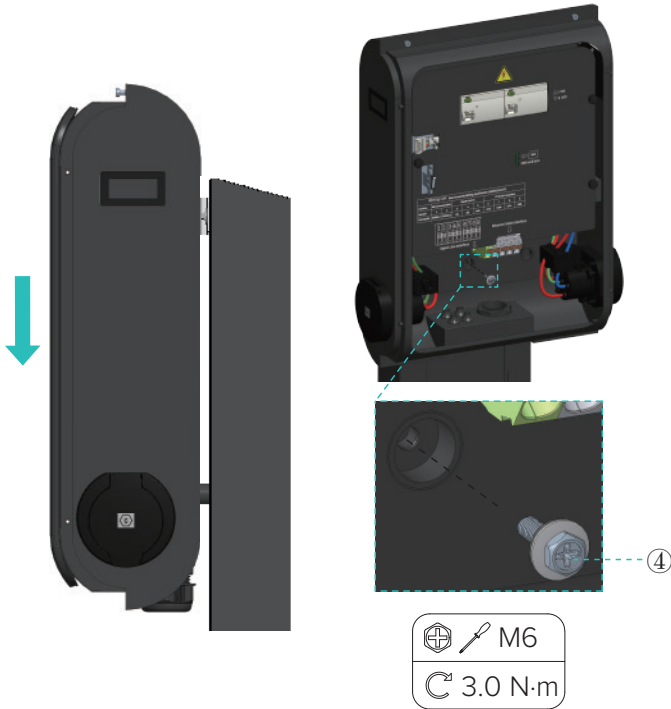

### Wiring Introduction

Open the cover.

The locations of the different wiring connections are shown below.

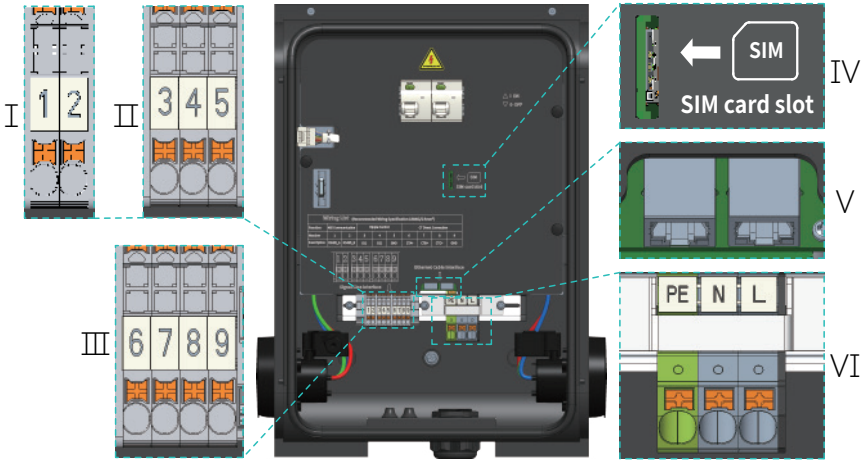

Single phase(7kW\*2)

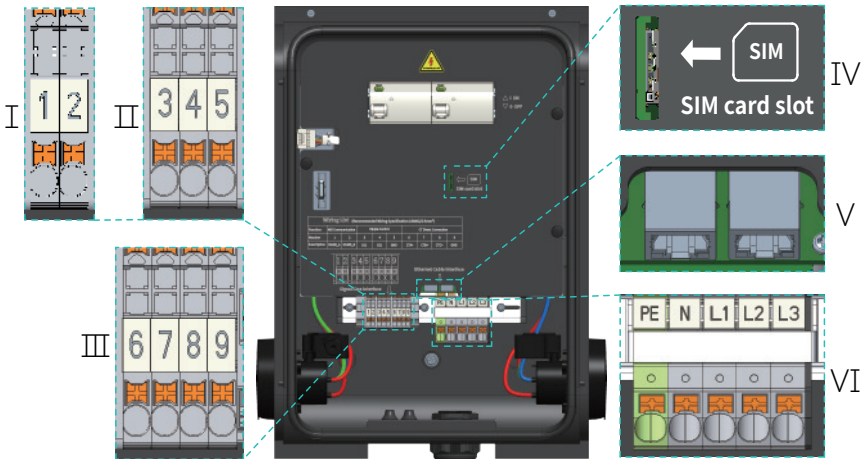

Three phase(11kW\*2 & 22kW\*2)

- I : RS485 Connections
- II : Ripple Control Connections
- III : CT Direct Connection

- IV : SIM card insertion area
- V : Ethernet Connections
- VI : Electrical Connections

### Electrical Connections

The EV Charger is equipped with built-in 30 mA AC leakage current detection and 6 mA DC leakage current monitoring, offering protection equivalent to a Type B Residual Current Device (RCD) and complying with the IEC-61851 international standard.

European standard EV Charger systems must be equipped with both a miniature circuit breaker (MCB) and a residual current protector (RCD). The RCD is required to disconnect all live conductors (including the neutral conductor). Users are advised to select compatible equipment based on the following recommendations or local standards:

#### Recommended External Protection Configuration

- 7.3 kW\*2 model: MCB (230 V/80 A)
- 11 kW\*2 model: MCB (400 V/40 A)
- 22 kW\*2 model: MCB (400 V/80 A)

During installation, local electrical safety regulations must take precedence.

Recommended to use wire diameter cable: 7.3 kW\*2: 10-16mm<sup>2</sup>, 11 kW\*2: 6-16mm<sup>2</sup>, 22 kW\*2: 10-16mm<sup>2</sup>. The outer diameter of the cable should be between 14-32 mm. Trim all cables to 110mm (as shown in the figure) and peel off the insulation sheath to expose the conductor by about 15mm.

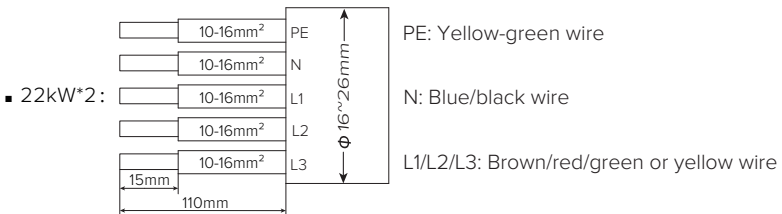
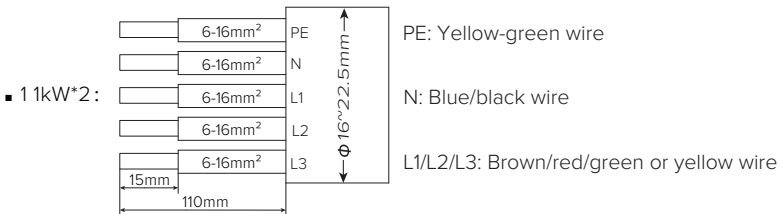
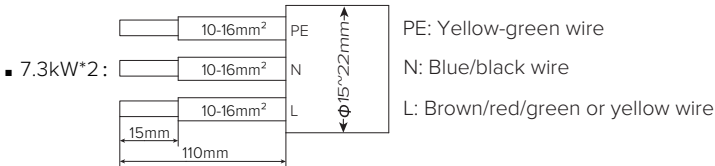

#### Note

Please refer to the local cable model and color during actual installation.

## Step 1:

Use crimping pliers to crimp the tubular terminal (G),(H) or ( I ) and cable.

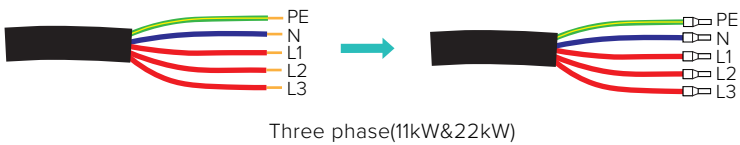
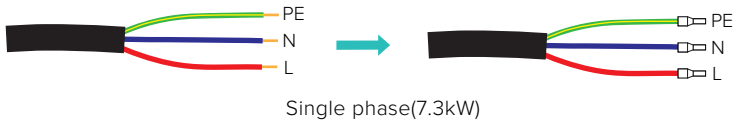

## Step 2:

Unscrew the gland nut and puncture the wire-through hole. Thread the cable through, and after completing Step 3, tighten the gland nut (The outer diameter of the cable should be between 14-32 mm).

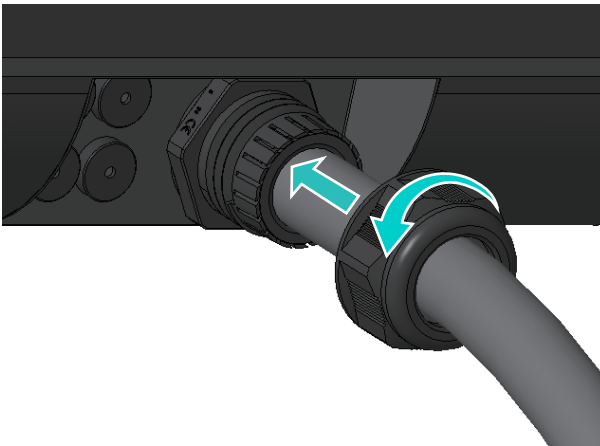

Step 3:  
Insert the wire firmly into the corresponding hole.

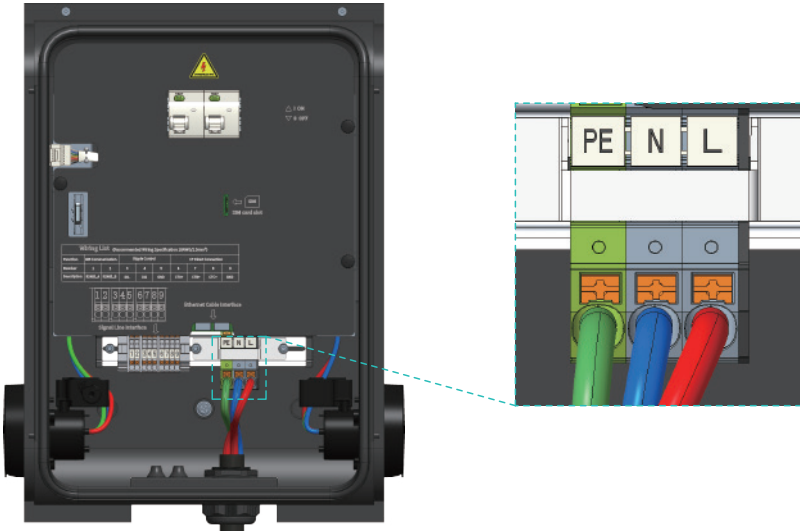

Single phase(7.3kW)

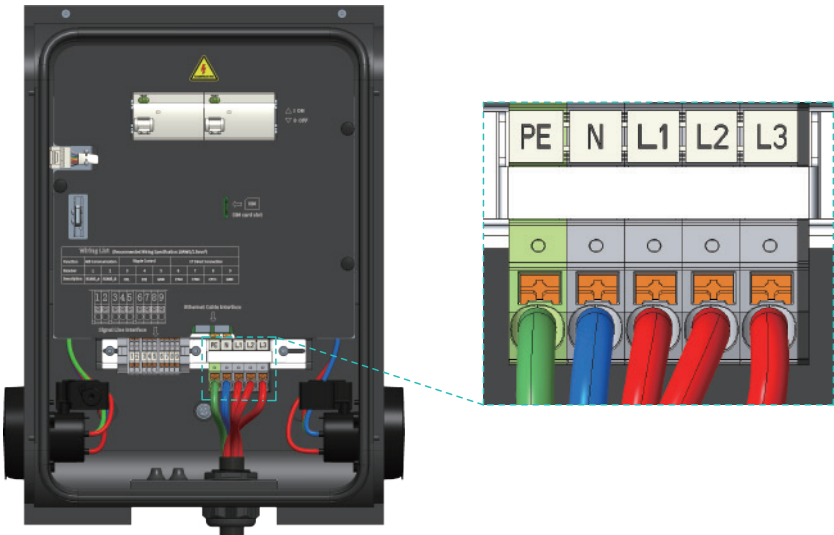

Three phase(11kW&22kW)

**RS485 Connections**

The RS485 Communication function needs to be realised in conjunction with a meter, and the wiring diagram of the meter can be referred to the following figure.

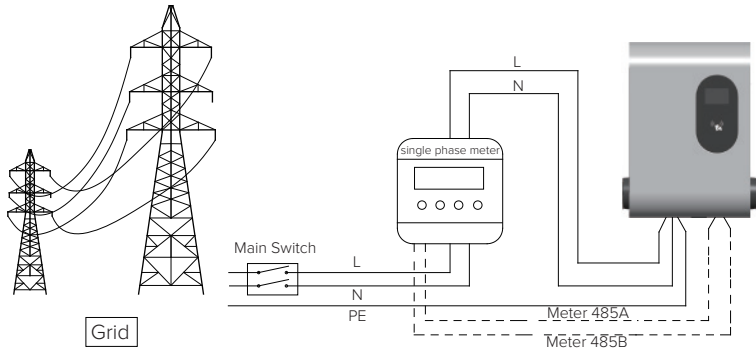

Single phase(7.3kW)

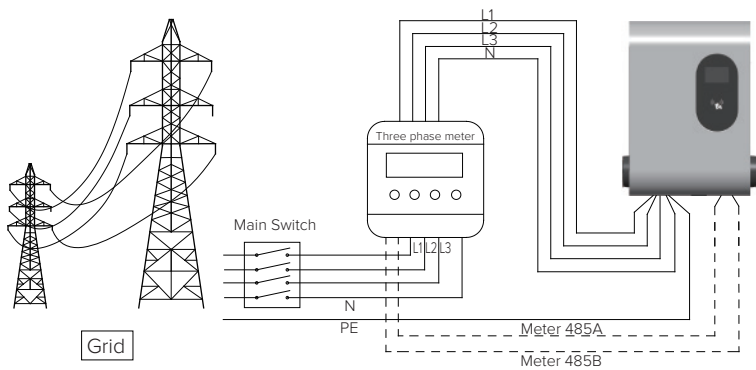

Three phase(11kW&22kW)

Trim all cables (wire diameter  $0.75\text{mm}^2$ ) to 50mm (as shown in the figure), peel off the insulation sheath to expose the conductor by about 12mm.



### Note

Please refer to the local regulations on the cable model and color during installation.

### Step 1:

Use crimping pliers to crimp the tubular terminal ( J ) and cable.

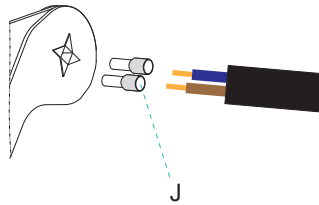

### Step 2:

1. Poke the M16 rubber arc ring through the center.
2. Pass the cable wires from the outside through the crossing holes.

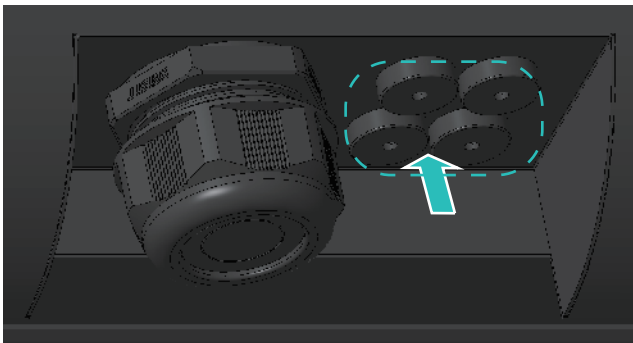

## Step 3:

Connect the cables to the corresponding terminal blocks according to the wiring diagram on the baffle.

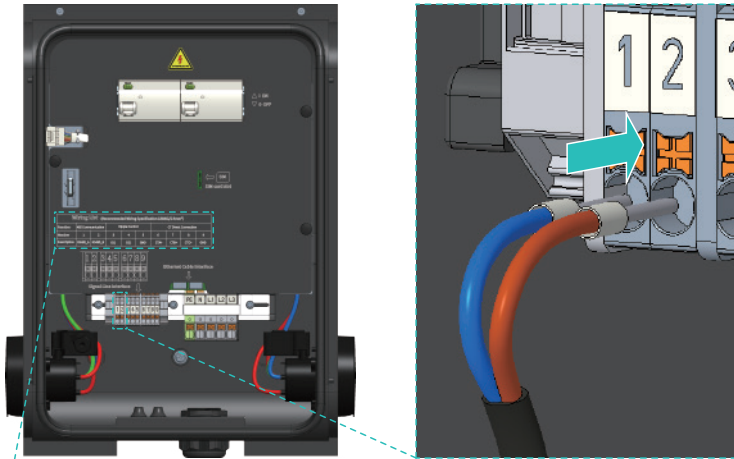

| Wiring List (Recommended Wiring Specification 18AWG/0.75mm <sup>2</sup> ) |                   |         |                |     |     |                      |     |     |     |
|---|-------------------|---------|----------------|-----|-----|----------------------|-----|-----|-----|
| Function  | 485 Communication |         | Ripple Control |     |     | CT Direct Connection |     |     |     |
| Number  | 1                 | 2       | 3              | 4   | 5   | 6                    | 7   | 8   | 9   |
| Description   | RS485_A           | RS485_B | DI1            | DI2 | GND | CTA                  | CTB | CTC | CND |

### Load curtailment Connections (wiring for the EV charger side)

Trim all cables (wire diameter  $0.75\text{mm}^2$ ) to 50mm (as shown in the figure), peel off the insulation sheath to expose the conductor by about 12mm.

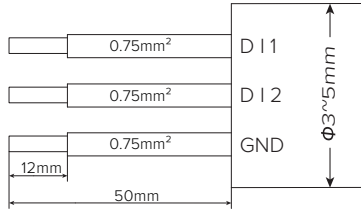

#### Note

- Please refer to the local regulations on the cable model and color during installation.
- See the third party's instructions on receiver for details of the wiring of the other end.

#### Step 1:

Use crimping pliers to crimp the tubular terminal ( J ) and cable.

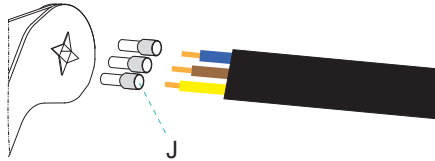

#### Step 2:

1. Poke the M16 rubber arc ring through the center.
2. Pass the cable wires from the outside through the crossing holes.

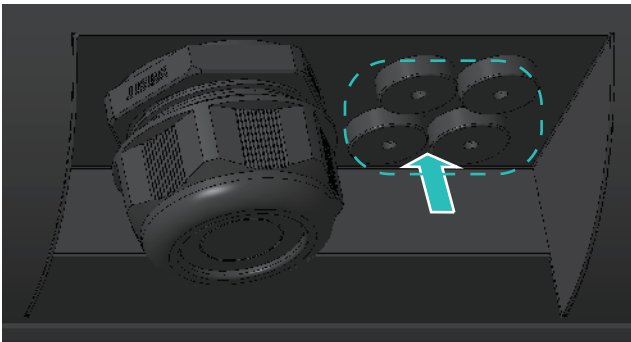

Step 3:

Connect the cables to the corresponding terminal blocks according to the wiring diagram on the baffle.

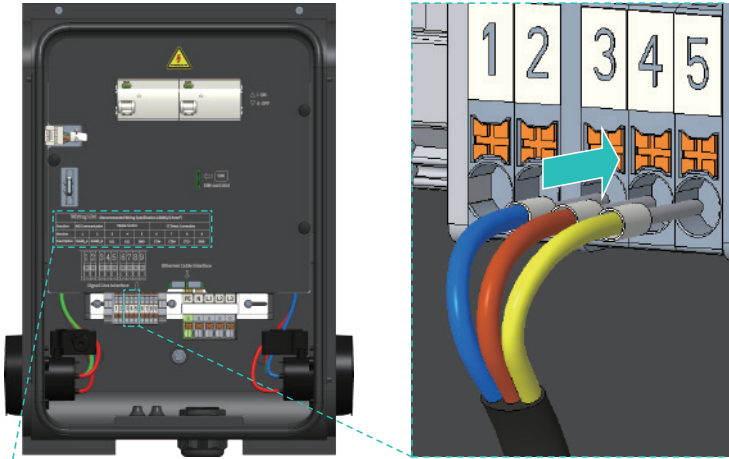

| Wiring List (Recommended Wiring Specification 18AWG/0.75mm <sup>2</sup> ) |                   |         |                |     |     |                      |                  |                  |     |
|---|-------------------|---------|----------------|-----|-----|----------------------|------------------|------------------|-----|
| Function  | 485 Communication |         | Ripple Control |     |     | CT Direct Connection |                  |                  |     |
| Number  | 1                 | 2       | 3              | 4   | 5   | 6                    | 7                | 8                | 9   |
| Description   | RS485_A           | RS485_B | DI1            | DI2 | GND | CTA                  | CTB <sub>I</sub> | CTC <sub>I</sub> | CND |

### CT Direct Connection (wiring for the EV charger side)

Trim all cables (wire diameter  $0.75\text{mm}^2$ ) to  $50\text{mm}$  (as shown in the figure), peel off the insulation sheath to expose the conductor by about  $12\text{mm}$ .

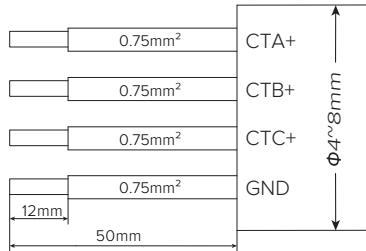

#### Note

- Please refer to the local regulations on the cable model and color during installation.
- See the third party's instructions on receiver for details of the wiring of the other end.

Step 1:

Use crimping pliers to crimp the tubular terminal ( J ) and cable.

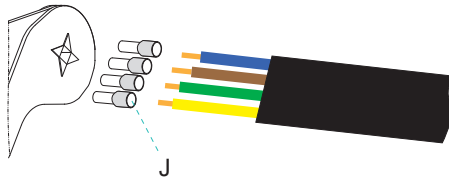

Step 2:

1. Poke the M16 rubber arc ring through the center.
2. Pass the cable wires from the outside through the crossing holes.

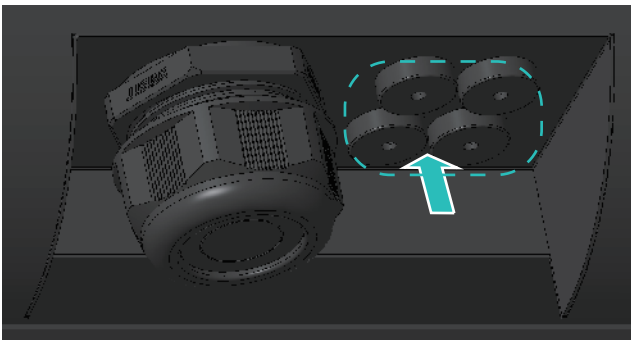

## Step 3:

Connect the cables to the corresponding terminal blocks according to the wiring diagram on the baffle.

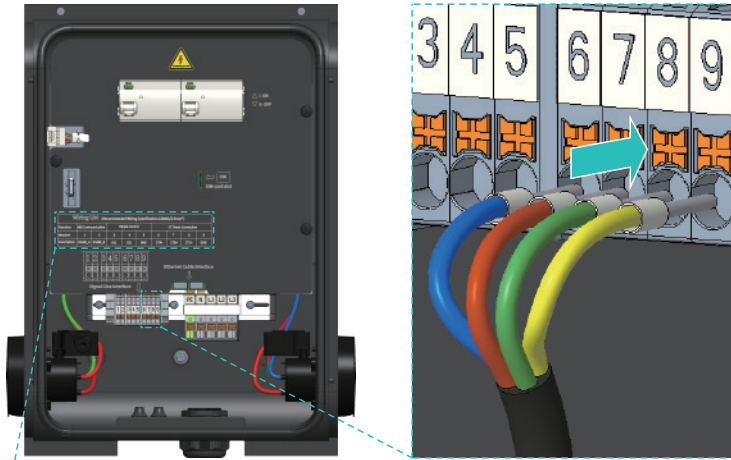

| Wiring List (Recommended Wiring Specification 18AWG/0.75mm <sup>2</sup> ) |                   |         |                |     |     |                      |                  |                  |     |
|---|-------------------|---------|----------------|-----|-----|----------------------|------------------|------------------|-----|
| Function  | 485 Communication |         | Ripple Control |     |     | CT Direct Connection |                  |                  |     |
| Number  | 1                 | 2       | 3              | 4   | 5   | 6                    | 7                | 8                | 9   |
| Description   | RS485_A           | RS485_B | DI1            | DI2 | GND | CTA                  | CTB <sub>I</sub> | CTC <sub>I</sub> | CND |

**Network connection**

- For Ethernet:

Step 1:

1. Poke the M16 rubber arc ring through the center.
2. Pass the Network cable without crimped crystal head from the outside through the crossing holes.

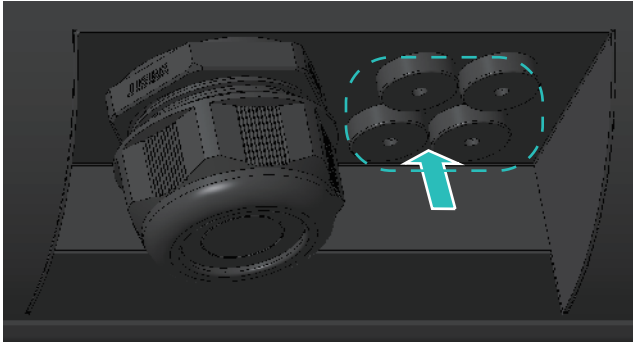

Step 2:

Crimp the cable to the crystal head.

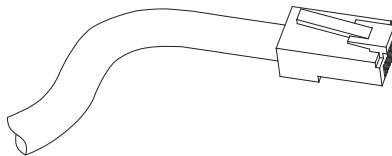

Step 3:  
Plug the cable into the corresponding position.

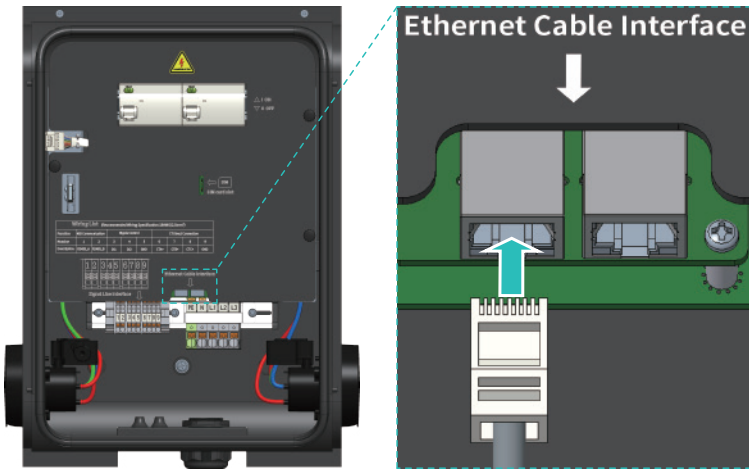

- For 4G:

Step :

Insert the SIM card (When inserting the SIM card, please make sure the direction must be the same as the picture shown below).

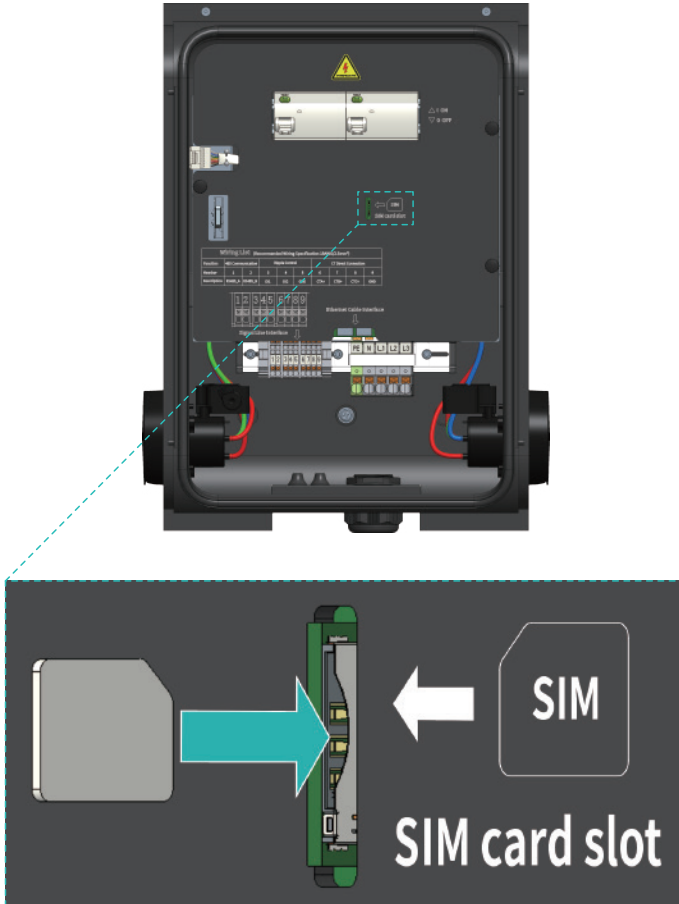

### Close the top cover

After completing the installation steps for the previous required contents, close the top cover to complete the EV Charger installation.

### Wall-mounted installation method

Step 1:

Flip the Residual Current Device switch up.

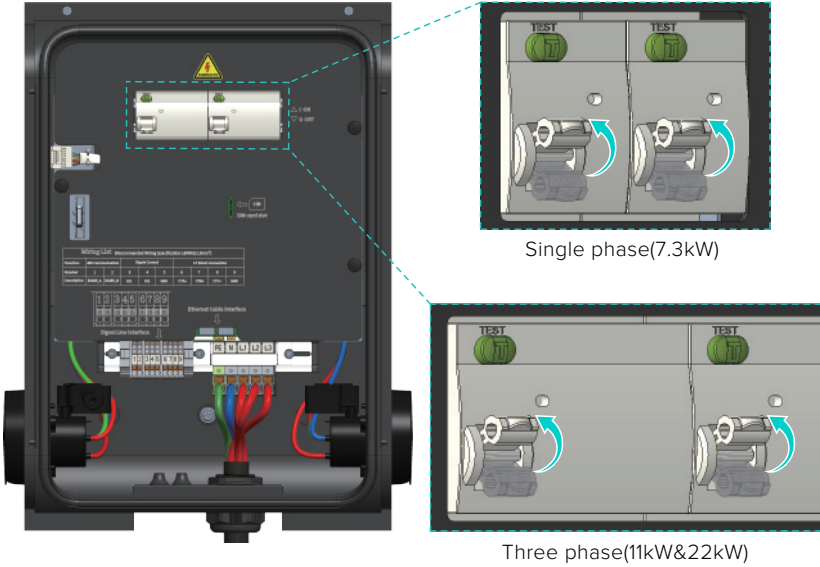

Step 2:

Plug in the wires as shown below.

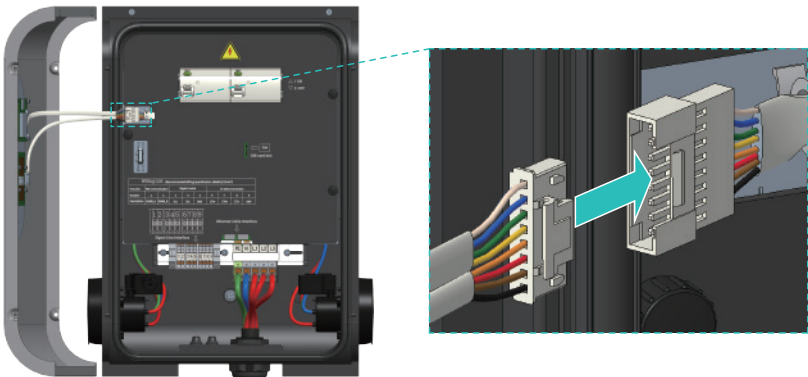

**Step 3:**

First, hook the top of the cover onto the main body, then secure the bottom into place.

**Step 4:**

Using the T20 Electric Screwdriver Bit (K) ,fix a total of 4 screws on the side to complete the installation.

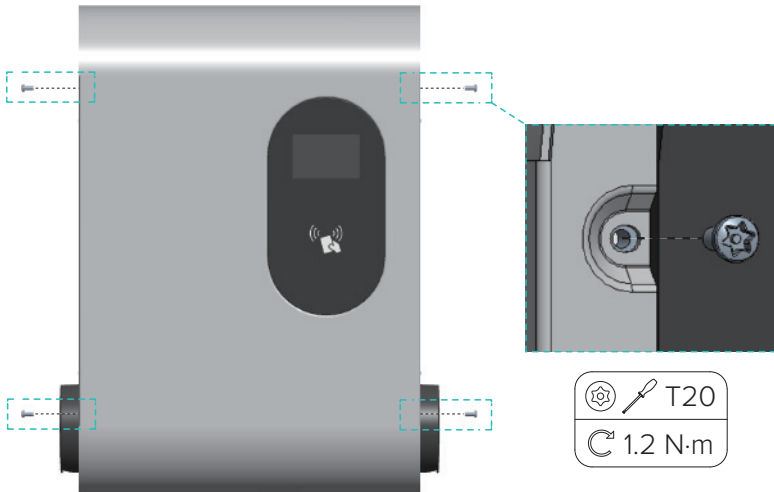

**Floor type / Vertical installation method**

Step 1:

1. Install the Cable Protective Cover (②) onto the Installation column.
2. Secure it with Torx-TR 20 Security Screw (③) on both sides.

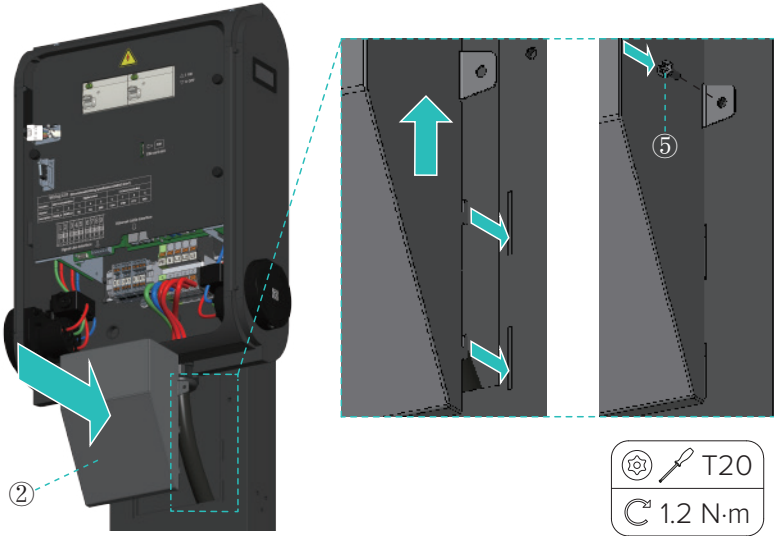

Step 2:

Flip the Residual Current Device switch up.

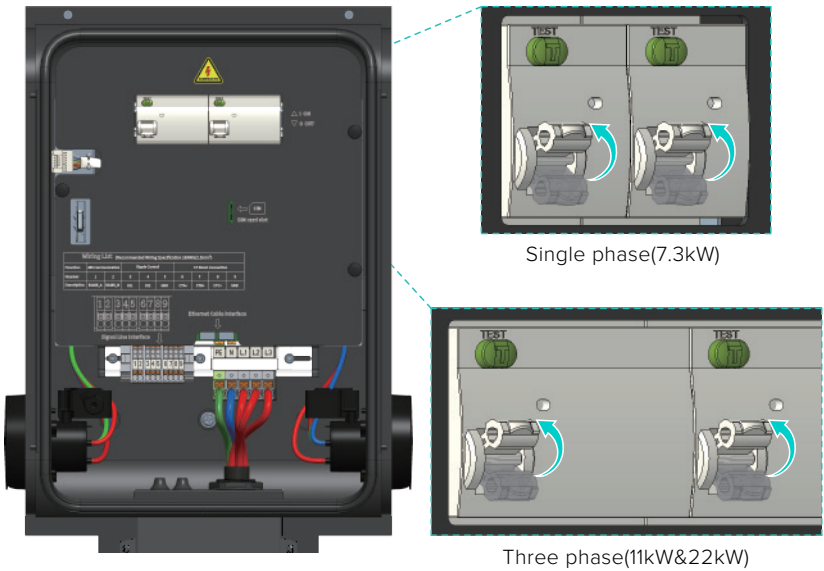

Step 3:  
Plug in the wires as shown below.

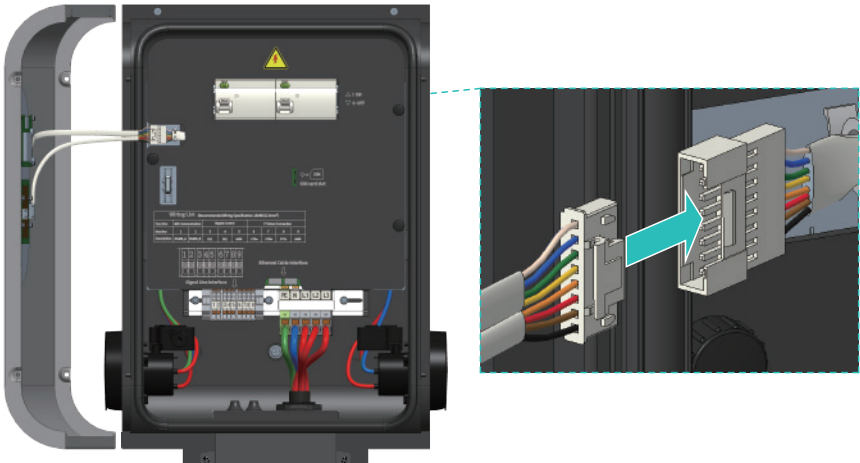

Step 4:  
First, hook the top of the cover onto the main body, then secure the bottom into place.

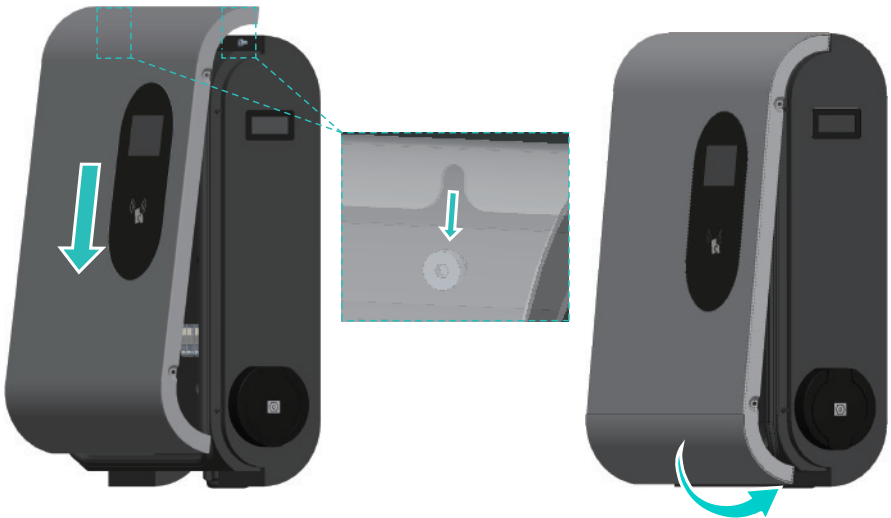

**Step 5:**

Using the T20 Electric Screwdriver Bit (K) ,fix a total of 4 screws on the side to complete the installation.

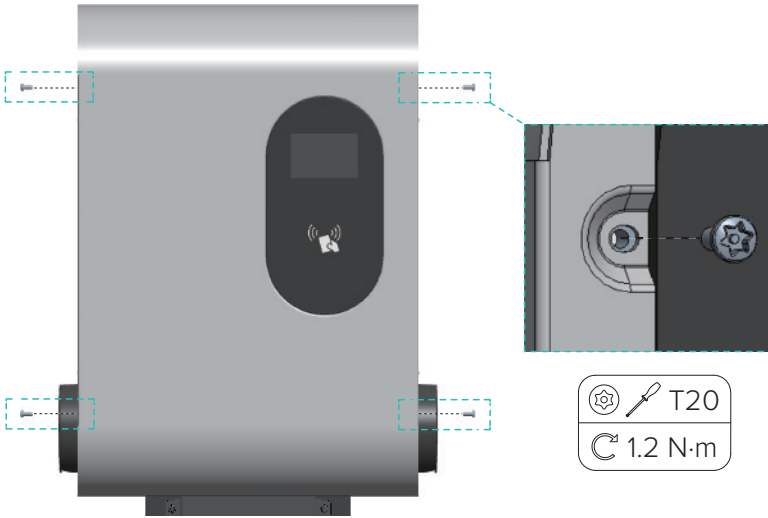

### Type 2 Plug Holder Installation (For Plug Version Models only)

For Plug Version Models, two Type 2 Plug Holder (L) are included for coiling and storing the plug cables.

#### Wall-mounted installation method

Step 1:

Mark the mounting hole positions on the wall with a marker pen (Recommended installation height: 0.8~1.0m).

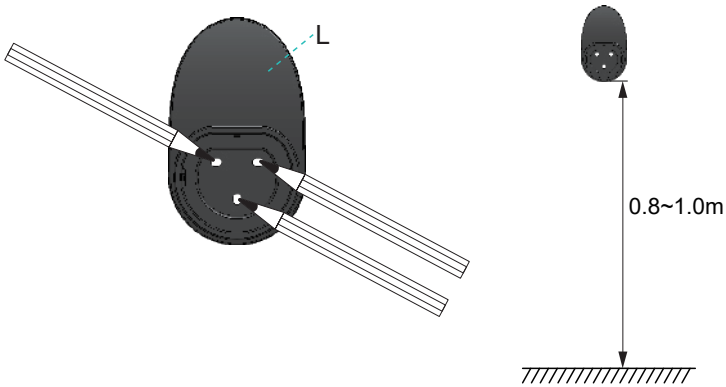

Step 2:

1. Use an  $\Phi 6$ mm drill bit to drill holes. The holes should be at least 40mm deep.
2. Insert the expansion tube from Type 2 Plug Holder (L) into the hole and hammer it firmly into place.

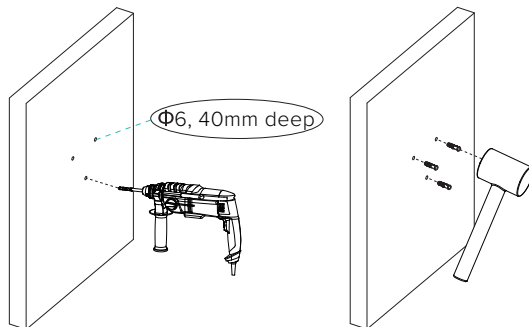

Step 3:  
Fix the Type 2 Plug Holder to the wall with screws from Type 2 Plug Holder (L).

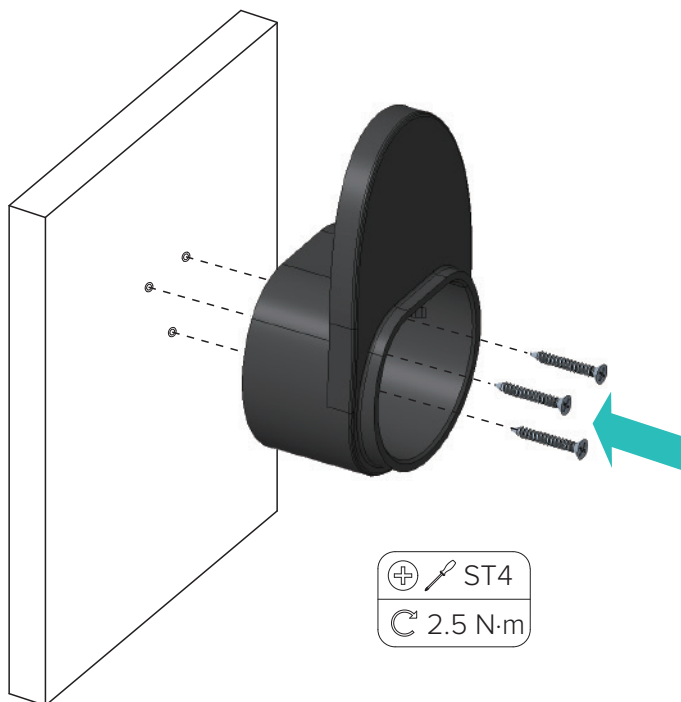

**Floor type / Vertical installation method**

Step :

Install the Type 2 Plug Holders (L) on both sides of the column and secure them with Torx-TR 20 Security Screw(⑤).

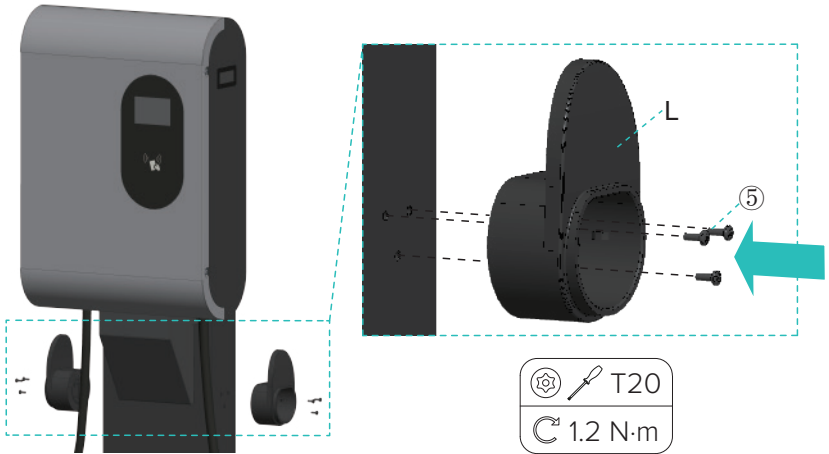

# 7 Operation

## 7.1 Charging mode and Operation

It is recommended to use this product in the commercial mode. The QR code payment function can only be enabled after completing network configuration and OCPP platform connection. For detailed operation instructions on network configuration and OCPP connection, please scan the following QR code to obtain the APP user manual.

Please follow the steps below to download our latest multilingual manual:  
Scan QR code → Select to download APP User Manual → Download



There are three charging modes which can be set on the corresponding interface of the APP: plug and charge, controlled, locked .

### A. Plug and Charge mode

Charging will start automatically after EV plugged in. If you want to stop charging, just press the stop button on the app.

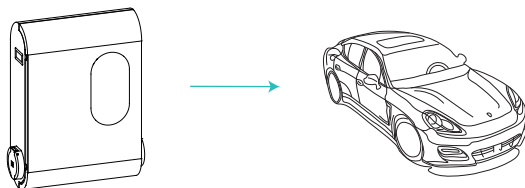

#### ▪ Start Charging:

1. Set the charger to the plug and charge mode
2. Insert the charging plug into the EV.
3. Charging session started.

#### ▪ Stop Charging:

1. Click to stop the charge on the APP.
2. Charging session end.

## B. Controlled mode

Initiate or cease charging on the APP or by swiping RFID card on this mode.  
You can also use APP for Reservations.

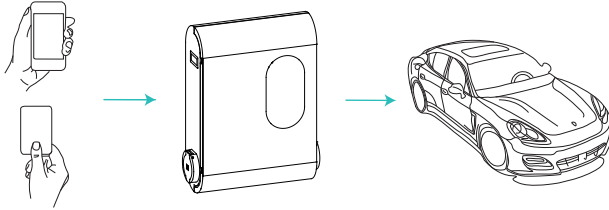

### Controlled mode with RFID card

#### ■ Start Charging:

1. Set the charger to the controlled mode.
2. Insert the charging plug into the EV.
3. Swipe card.
4. Charging session started.

#### ■ Stop Charging:

1. Swipe card.
2. Charging session end.

### Controlled mode with APP

#### ■ Start Charging:

1. Set the charger to the controlled mode.
2. Insert the charging plug into the EV.
3. Click to start the charge on the APP.
4. Charging session started.

#### ■ Stop Charging:

1. Click to stop the charge on the APP.
2. Charging session end.

## C. Locked mode

On this mode, the charger is locked and can not work.

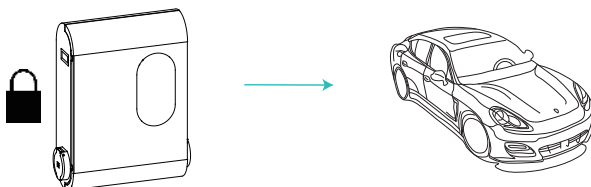

## 7.2 Display Descriptions

### 7.2.1 Standby Screen

**Status Description:** Presented when the EV Charger is idle and available.

**Display Content:** Clearly indicates the EV Charger is ready for use.

**User Actions:** Select an available connector (#1 or #2) and insert the corresponding charging gun. The system will then automatically transition to the Authorization Interface.

Or, directly swipe an authentication card (e.g., RFID card/mobile NFC) on the standby interface. The system will then automatically transition to the Authorization Interface.

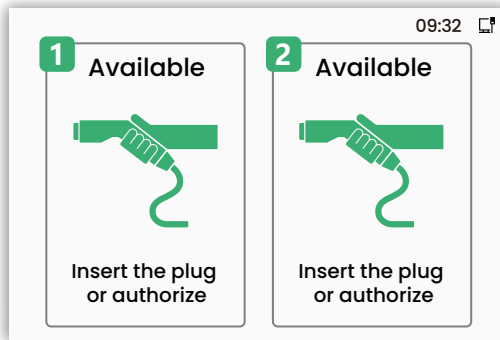

An icon in the top-right corner of the screen displays real-time network connectivity status.

### 7.2.2 Authorization Screen

**Status Description:** This interface facilitates the authentication process to initiate a charging session. Its displayed content depends on the sequence of user actions.

**User Actions & Prompts:**

**Charging Gun Inserted First:** The screen will explicitly prompt the user: "Please swipe card to start charging"

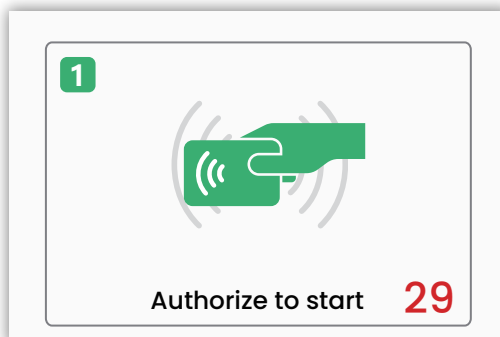

Card Swiped First: The screen will explicitly prompt the user: "Please insert charging gun to continue".

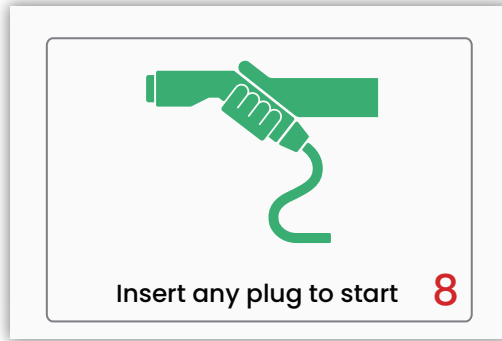

### 7.2.3 Charging Screen

**Status Description:** Presented once a charging session is successfully initiated, displaying real-time key parameters of the charging process.

**Display Content (Typical Parameters):**

Real-time Charging Power (kW)

Current Charged Energy (kWh)

Elapsed Charging Time (for the current session)

Current Accumulated Charging Cost

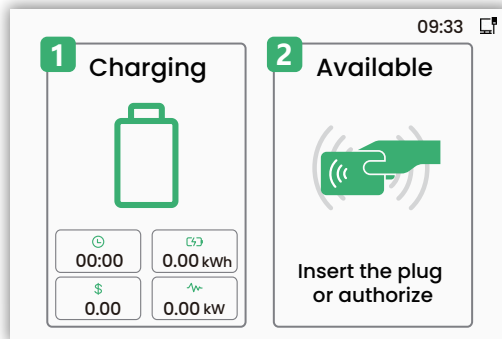

### 7.2.4 Order Settlement Screen

**Status Description:** Automatically displayed upon normal termination of a charging session.

**Display Content:** Clearly presents a detailed summary of the completed charging session (typically labeled as "Charging Details").

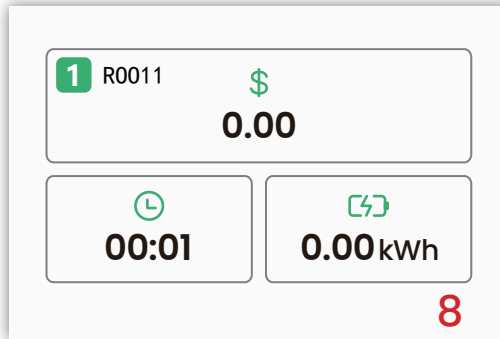

### 7.2.5 Upgrade screen

**Status Description:** Presented when the EV Charger initiates a firmware update.

**Display Content:** Prominently labelled 'Downloading' indicates that the device is undergoing an internal software update and will be temporarily out of service in the meantime.

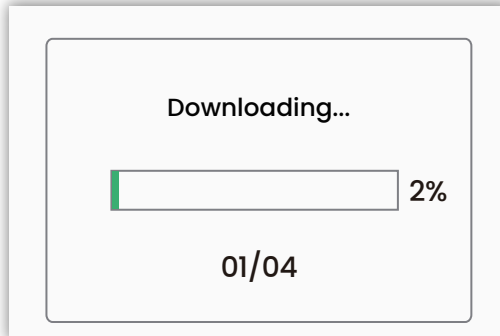

### 7.2.6 Error Screen

**Status Description:** Presented when the EV Charger detects a system fault, operational issue, or abnormal state.

**Display Content:** The system displays a corresponding error code and concise error message description based on the specific error type detected.

**User Guidance:** On-screen information directs the user towards necessary actions (e.g., retry, contact support) .

**Example Scenario:**

Error Message: "E1017"

Possible Cause: Electronic lock fault, Set the electronic lock status to the correct position. Or seek help from the installers/distributors.

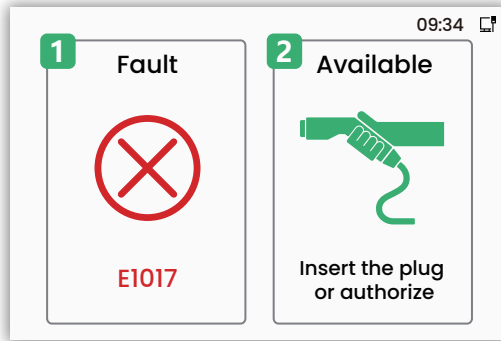

## 8 Maintenance

In the event of a device malfunction, users can access fault information via the mobile application (APP) or look up error codes on the device screen. The LCD only displays the fault status, and the error code is displayed according to 'EX000'.

X: indicates the location of the error

0: Charger system error

1: Charger connector 1 error

2: Charger connector 2 error

| No.                     | Fault code on app                      | Solution  |
|-------------------------|--|---|
| E0006                   | Ground fault                           | Ensure the EV Charger is grounded correctly.  |
| E0005                   | Access control fault                   | Restart the charger and check if the charger is back to normal.<br>Or seek help from the installers/distributors.     |
| E1001<br>E1002<br>E1003 | Over voltage                           | Wait for the grid voltage to return to normal.<br>Or seek help from the installers/distributors.                      |
| E1004<br>E1005<br>E1006 | Under voltage                          | Wait for the grid voltage to return to normal.<br>Or seek help from the installers/distributors.                      |
| E1007<br>E1008<br>E1009 | Over current                           | Seek help from the installers/distributors.   |
| E1010                   | Over temperature of charging interface | Wait for the temperature of charging interface to return to normal.<br>Or seek help from the installers/distributors. |
| E1012                   | Residual current detected              | Unplug the vehicle and plug in again.<br>Seek help from the installers/distributors.                                  |
| E1014                   | Abnormal CP voltage                    | Seek help from the installers/distributors.   |
| E1016                   | Abnormal AC output contactor           | Seek help from the installers/distributors.   |
| E1017                   | Electronic lock fault                  | Set the electronic lock status to the correct position.<br>Or seek help from the installers/distributors.             |
| E1019                   | Internal meter communication failure   | Seek help from the installers/distributors.   |
| E1020                   | on-board overtemperature fault         | Wait for the temperature inside the EV Charger to return to normal.<br>Or seek help from the installers/distributors. |
| E1021                   | Control board communication failure    | Seek help from the installers/distributors.   |

# 9 Decommissioning

## 9.1 Dismantling the charger

- Disconnect the charger from AC input and AC output.
- Disconnect communication and optional connection wirings. Remove the charger from the bracket.
- Remove the bracket if necessary.

## 9.2 Packaging

If possible, please pack the charger with the original packaging. If it is no longer available, you can also use an equivalent box that meets the following requirements.

- Suitable for loads more than 30 kg.
- Contains a handle.
- Can be fully closed.

## 9.3 Storage and Transportation

Store the charger in dry place where ambient temperatures are always between -40°C - + 70°C. Take care of the charger during the storage and transportation; keep less than 4 cartons in one stack. When the charger or other related components need to be disposed of, please ensure it is carried out according to local waste handling regulations. Please be sure to deliver any charger that needs to be disposed from sites that are appropriate for the disposal in accordance with local regulations.

## 9.4 Network Port Exposure Statement

Due to essential functional requirements, this device exposes the following network ports. These ports are opened upon device startup and closed upon device shutdown.

| Port | Protocol | Purpose   |
|------|----------|---|
| 502  | TCP      | Provides MODBUS TCP services for system integration.                    |
| 5353 | UDP      | Provides mDNS (Multicast DNS) services for device discovery in the LAN. |

### Note

- Port exposure is necessary for normal operation and interoperability.
- Ensure proper network security measures (e.g., firewalls, access control) are implemented to restrict unauthorized access.



If you need more information, please follow us on YouTube.  
scan the QR code or visit  
<https://www.youtube.com/@foxess5669>

---

**Address: FOXESS CO., LTD. No. 939, Jinhai 3rd Road, Longwan District, Wenzhou, Zhejiang, China**  
**Tel: +86(510) 68092998(General) +86(510) 68101679 (Sales)**  
**Website: [www.fox-ess.com](http://www.fox-ess.com)**