USER MANUAL

7.3kW&11kW&22kW AC EV Charger

A7300P1-E-B
A011KP1-E-B
A022KP1-E-B

A7300S1-E-B
A011KS1-E-B
A022KS1-E-B

A7300S-T2S-B
A011KS-T2S-B
A022KS-T2S-B



Table of Contents

1. Notes on This Manual	1
1.1 Scope of Validity	1
1.2 Target Group	1
1.3 Symbols Used	1
2. Safety	3
3. Packing List	4
4. Introduction	5
5. Technical Data	6
6. Installation	8
6.1 Loading & Unloading of Products	8
6.2 Check before Installation	8
6.3 Installation	8
7. Operation	27
8. Maintenance	29
9. Decommissioning	30
9.1 Dismantling the Charger	30
9.2 Packaging	30
9.3 Storage and Transportation	30

1 Notes on this Manual

1.1 Scope of Validity

This manual describes the assembly, installation, commissioning, maintenance and troubleshooting of the following model (s) of products:

A7300P1-E-B

A7300S1-E-B

A7300S-T2S-B

A011KP1-E-B

A011KS1-E-B

A011KS-T2S-B

A022KP1-E-B

A022KS1-E-B

A022KS-T2S-B

1.2 Target Group

This manual is for qualified electricians. The tasks described in this manual can only be performed by qualified electricians.

1.3 Symbols used

The meanings of the symbols appearing in this manual are explained below:



"Warning" indicates a hazardous situation which, if not avoided, could result in death or serious injury.









"Note" provides important tips and guidance.



It means the operation on the product is correct.

Symbols on the EV Charger

Symbol	Explanation
	CE mark. The charger complies with the requirements of the applicable CE guidelines.
	Beware of hot surface. The charger can become hot during operation. Avoid contact during operation.
	Danger of high voltage. Danger to life due to the high voltage in the charger!
	UKCA mark. The charger complies with the requirements of the applicable UKCA guidelines.
	Please read the user manual carefully.
	The charger can not be disposed together with the household waste.
	RCM mark. The charger complies with the requirements of the applicable RCM guidelines.

2 Safety

EV chargers are designed and tested in accordance with international safety requirements. However, certain safety precautions must be taken when installing and operating this. The installer must read and follow all instructions, cautions and warnings in this installation manual.

- All operations including transport, installation, start-up and maintenance, must be carried out by qualified, trained personnel.
- The electrical installation & maintenance of the charger shall be conducted by a licensed electrician and shall comply with local wiring rules and regulations.
- Before installation, check the unit to ensure it is free of any transport or handling.
- Unauthorized removal of necessary protections, improper use, incorrect installation and operation may lead to serious safety and shock hazards or equipment damage.
- Do not install the equipment in adverse environmental conditions such as in close proximity to flammable or explosive substances; in a corrosive or desert environment; where there is exposure to extreme high or low temperatures; or where humidity is high.
- Do not use the equipment when the safety devices do not work or are disabled.
- Use personal protective equipment, including gloves and safety goggles during the installation.
- Inform the manufacturer about non-standard installation conditions.
- Do not use the equipment in case of any operation anomalies. Avoid temporary repairs.
- All repairs should be carried out using only approved spare parts, which must be installed in accordance with their intended use and by a licensed contractor or authorized service partner.
- Liabilities arising from commercial components are delegated to their respective manufacturers.

3 Packing List

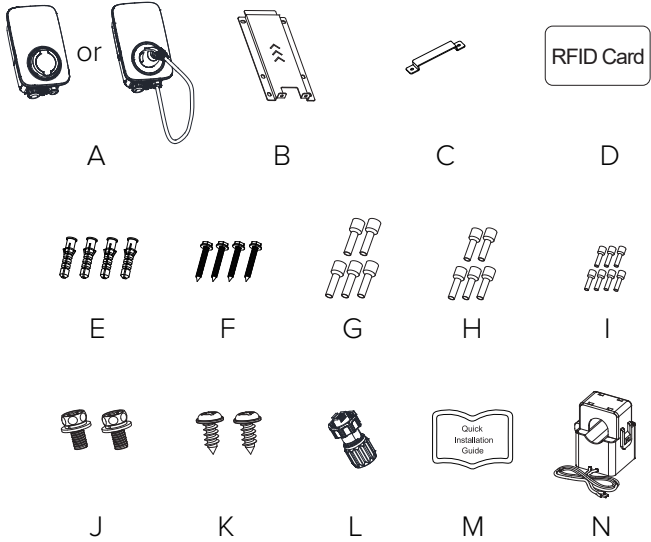

No.	Name	Quantity
A	EV Charger (Plug or Socket Version)	1
B	Mounting Backplate	1
C	Mounting Bracket	1
D	RFID Card	2
E	Expansion Pipe ($\Phi 8 \times 40$)	4
F	Expansion Screw (ST6*40)	4
G	Tubular Terminal (EVN10-12)	5
H	Tubular Terminal (EVN6012)	5
I	Tubular Terminal (EVN0508)	7
J	Screw Assembly (M4*10)	2
K	Self-tapping Screw (ST4.2*9.5)	2
L	RJ45 Connectors	1
M	Quick Installation Guide	1
N	CT Clamp (for single - phase)	1

4 Introduction

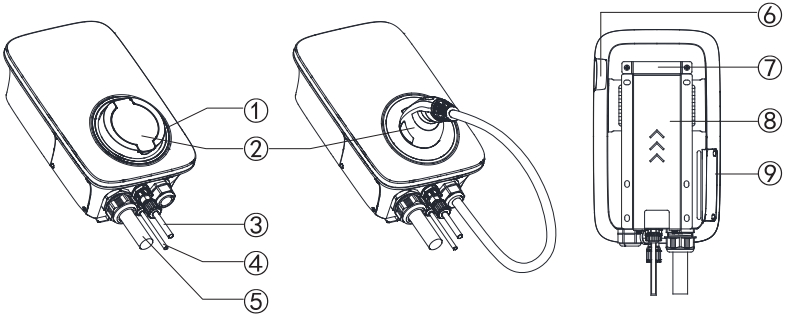

① Meaning of lights

- Green breathing light - standby status
- Blue steady - EV Plug inserted status
- Blue breathing light - charging start status/pause
- Blue running light - charging status
- Green steady - charging end status
- Red steady - charger fault, shutdown protection
- Yellow steady - locked status

② Socket or Plug

③ RJ45 Communication wire

④ RS485 Communication wire

⑤ Incoming cable

⑥ Stop button

⑦ Mounting Bracket

⑧ Mounting Backplate

⑨ Side cover

5 Technical Data

FOX ESS 7.3kW&11kW&22kW AC-CHARGER SPEC						
Model	A7300P1-E-B	A7300S1-E-B A7300S1-T2S-B	A011KP1-E-B	A011KS1-E-B A011KS-T2S-B	A022KP1-E-B	A022KS1-E-B A022KS-T2S-B
Input						
Wiring Scheme	L/N/PE		3L/N/PE			
Rated voltage	230Vac, ±20%		400Vac, ±20%			
Rated current	32A		16A	32A		
Rated frequency	50/60Hz					
Standby Power Consumption	≤10W					
Output						
Output voltage	230Vac, ±20%		400Vac, ±20%			
Maximum output current	32A		16A	32A		
Rated power	7.3kW		11kW	22kW		
Power Accuracy	≤2%					
Interaction method						
Connector Type	IEC 62196 Type 2 Cable, Type 2 Socket, Type 2 Socket With Shutter					
Start-up mode	APP/RFID Card/Plug&Charge					
Communication method						
RFID	Operating Frequency Band:13.56MHz Maximum output power:51.74dBμV/m@3m					
Bluetooth	Operating Frequency Band: 2402~2480 MHz (TX/RX) Maximum output power:17.72dBm					
WiFi(2.4GHz)	Operating Frequency Band: 2412-2472MHz (TX/RX); 2422-2462MHz (TX/RX) Maximum output power: 19.28dBm					
4G LTE	Operating Frequency Band: GSM 900: 880-915MHz (Uplink), 925-960MHz (Downlink) DCS 1800: 1710-1785MHz (Uplink), 1805-1880MHz (Downlink) LTE Band 1: 1920-1980MHz (Uplink), 2110-2170MHz (Downlink) LTE Band 3: 1710-1785MHz (Uplink), 1805-1880MHz (Downlink) LTE Band 7: 2500-2570MHz (Uplink), 2620-2690MHz (Downlink) LTE Band 8: 880-915MHz (Uplink), 925-960MHz (Downlink) LTE Band 20: 832-862MHz (Uplink), 791-821MHz (Downlink) LTE Band 28: 703-748 MHz (Uplink), Downlink: 758-803 MHz (Downlink) LTE Band 38: 2570-2620 MHz (Uplink), Downlink: 2570-2620 MHz (Downlink) LTE Band 40: 2300-2400 MHz (Uplink), Downlink: 2300-2400 MHz (Downlink) Maximum output power: GSM: ≤35dBm (GSM 900); ≤32dBm (GSM 1800) LTE: ≤25dBm					
Ethernet (Rj45)	Yes					
OCP	1.6J or 2.0J					
Communication with the vehicle	ISO 15118 hardware ready					
Environment						
Installation method	Wall mounting/column mounting					
Working temperature	-30°C~50°C					
Working humidity	5%~95% no condensation					
Altitude	≤2000m					

Size and weight	
Size	320*190*130 mm (Plug),320*190*144 mm (Socket)
Weight	≤6.3kg (Plug),≤3.2kg(Socket)
Safety	
Waterproof rating	Body-IP65, Socket-IP55
Anti-collision grade	IK08
Residual current detection*	6mA DC / 30mA AC
Protection function	Over/Under Voltage Protection, Overcurrent Protection, Leakage Current, Ground Protection, Surge Protection, Overtemperature Protection, Tamper Protection, PEN Salt-mist-resistant, UV-resistant Treatment
Certification	CE/UKCA/CB/RCM
Certification standard	EN/IEC 61851-1: 2019, EN/IEC 61851-21-2: 2021

*Internal RCD-DD meets the trip time characteristics specified in IEC 62955

*External RCCB is required

*Select Type A or Type B according to local regulations.

6 Installation

6.1 Loading & Unloading of Products

To ensure safety, the following points should be paid attention to:

- All accessories are placed separately during transportation or handling.
- Avoid violent shock and impact, and take it lightly.
- Avoid inversion.

6.2 Check before Installation

- Open the EV Charger packaging, and check the accessories according to the packing list.
- Check whether the EV Charger is damaged during transportation. If there is any damage or missing parts, do not boot up the charger and inform the carrier and dealer immediately. Determine if this machine is the model that you want to purchase.

Note

Please keep the packing boxes and packaging materials for future handling.

6.3 Installation

■ Pre-installation preparation

The following tools are required for the installation:

Cross screwdriver, special plum screwdriver, stripping pliers, pressing pliers.

■ Installation precautions

Please strictly follow the wiring requirements and correct access.

Please confirm that all fasteners are locked to secure the EV Charger.

■ Installation environment and location

- The area where the charger will be placed must be well ventilated, far away from water, combustible gas and corrosive agent.
- Ensure that the ground or installation platform can withstand the weight of the charger.
- If the charger is disassembled and used in the low temperature environment, water droplets condensation phenomenon may occur. Ensure that the charger is thoroughly dry before installation or use, avoiding the danger of electric shock.
- Please place the charger near the mains input so that installers or users can disconnect the mains input switch and cut off the power supply timely in case of emergency.

Note

The installation needs to comply with local installation requirements and safety regulations.

Ensure that the wall or column is vertical or tilted 15 ° backward before installation.

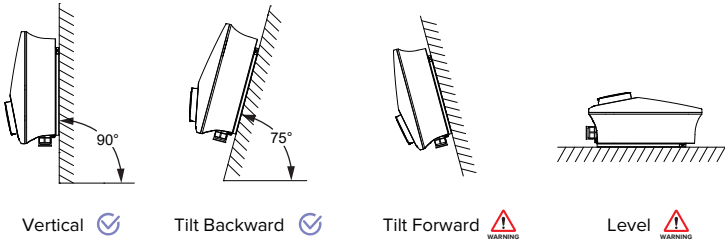

■ Wall-mounted installation method

Step 1:

1. Mark 4 holes according to the installation positioning card on the wall.
2. Use an 8mm drill bit to drill holes. The holes should be at least 50mm deep.
3. Clean the hole position.

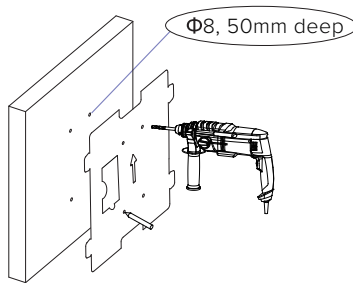

Step 2:

Insert the expansion pipe (E) into the hole and fix it tightly with a rubber hammer.

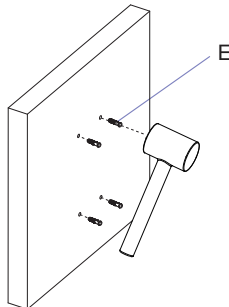

Step 3:
Fix the Mounting backplate (B) to the wall with screws (F).

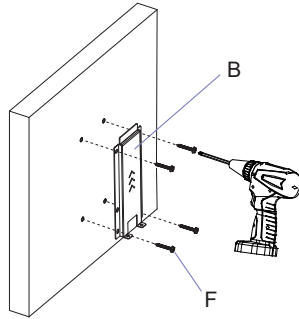

Step 4:
Fix the Mounting bracket (C) onto the EV Charger with screws (K).

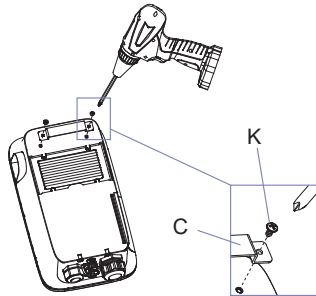

Step 5:
1. Hang the EV Charger into the Mounting backplate.
2. Tighten the screws (J) to complete the installation.

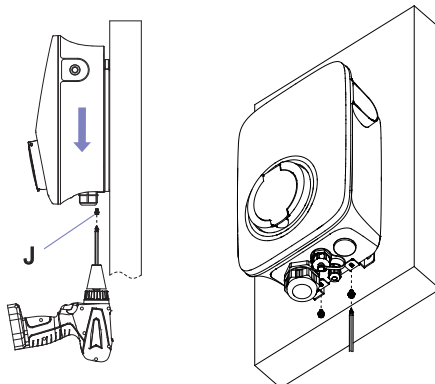

▪ Floor type / Vertical installation method

Column packing list:

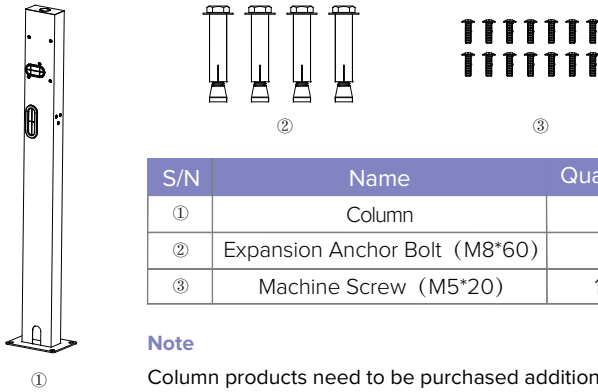

Step 1:

1. Drill four 60 mm deep holes spaced 170*120 mm apart using a 12 mm drill bit.
2. Drill one $\Phi 60$ mm outlet hole in the center.
3. Clean the hole position.

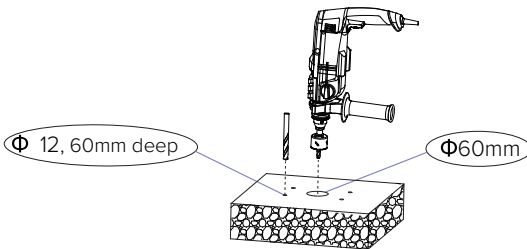

Step 2:

Install the expansion anchor bolt (②) and fix them with a wrench.

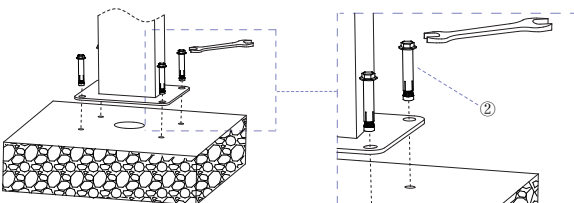

Step 3:

Router the input wire into the column hole through the bottom of the column.

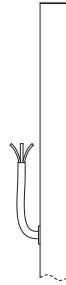

Step 4:

Fix the Mounting backplate (B) to the column with screws (③).

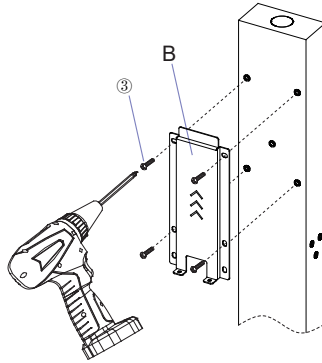

Step 5:

Fix the Mounting bracket (C) onto the EV Charger with screws (K).

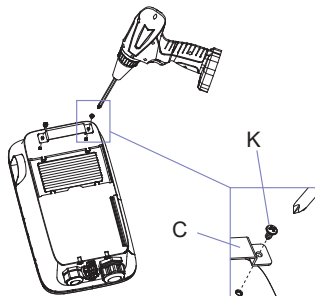

Step 6:

1. Hang the EV Charger into the Mounting backplate.
2. Tighten the screws (J) to complete the installation.

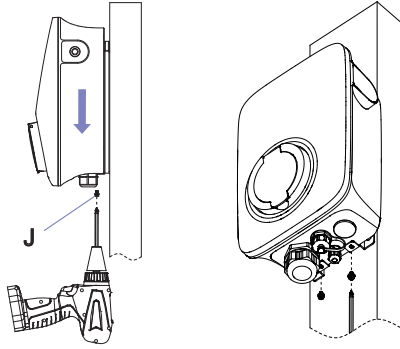

Wiring Introduction

Open the side cover.

The locations of the different wiring connections are shown below.

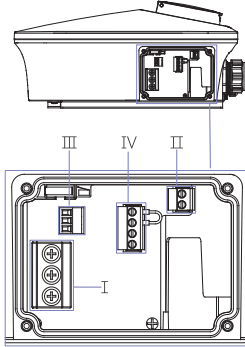

Single phase(7.3kW)

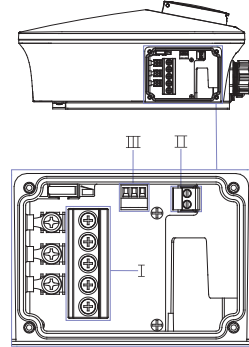

Three phase(11kW&22kW)

Single phase(7.3kW)

- I : Electrical connections.
- II : Communication wiring connections.
- III : Load curtailment connections.
- IV : CT sensor connections.

Three phase(11kW&22kW)

- I : Electrical Connections.
- II : Communication wiring connections.
- III : Load curtailment connections.

Electrical Connections

The EV Charger is equipped with built-in 30 mA AC leakage current detection and 6 mA DC leakage current monitoring, offering protection equivalent to a Type B Residual Current Device (RCD) and complying with the IEC-61851 international standard. Note that regulations in certain countries or regions may require additional external protection devices. Users are advised to select compatible equipment based on the following recommendations or local standards

Recommended External Protection Configuration

- ▶ 7.3 kW model: 30 mA Type A RCBO (230 V/40 A)
- ▶ 11 kW model: 30 mA Type A RCBO (400 V/20 A)
- ▶ 22 kW model: 30 mA Type A RCBO (400 V/40 A)

During installation, local electrical safety regulations must take precedence. Supplemental protective measures, such as a combined RCD+MCB or an integrated RCBO, may be applied as needed.

It is recommended to use wire diameter 6-10mm² cable.

Trim all cables to 50mm (as shown in the figure) and peel off the insulation sheath to expose the conductor by about 10mm.

Single phase(7.3kW)

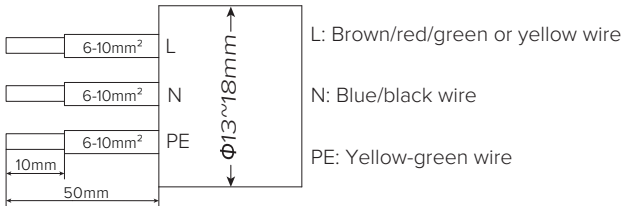

Three phase(11kW&22kW)

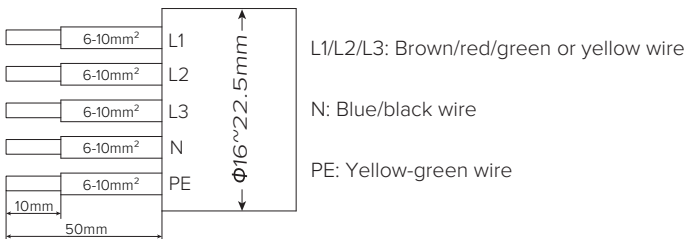

Note

Please refer to the local cable model and color during actual installation.

Step 1:

Use crimping pliers to crimp the tubular terminal (G) or (H) and cable.

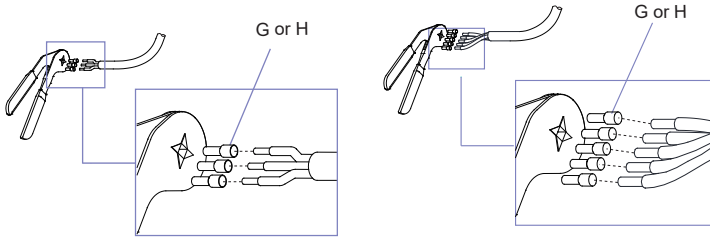

Single phase(7.3kW)

Three phase(11kW&22kW)

Step 2:

Unscrew the gland nut and puncture the wire-through hole.

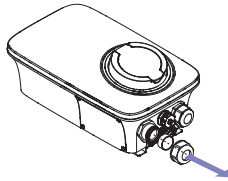

Step 3:

Open the side cover and install the cable (wire diameter $\varnothing 13-18\text{mm}$).

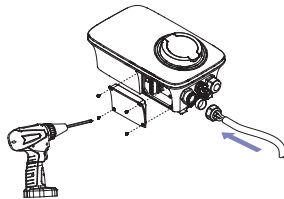

Step 4:

Install the cable into the terminal block and fix it, and tighten the gland nut.

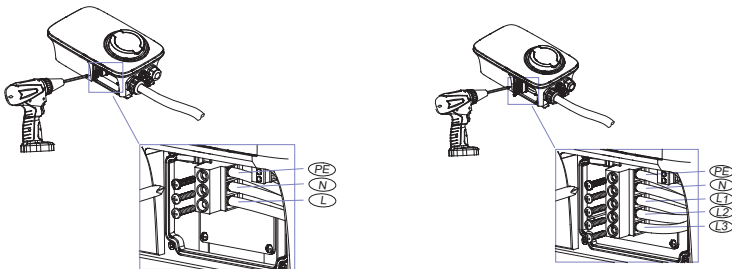

Single phase(7.3kW)

Three phase(11kW&22kW)

Communication wiring connections

Trim all cables (wire diameter 0.2mm²) to 15mm (as shown in the figure), peel off the insulation sheath to expose the conductor by about 8mm.



Note

Please refer to the local regulations on the cable model and color during installation.

The RS485 Communication function needs to be realised in conjunction with a meter, and the wiring diagram of the meter can be referred to the following figure.

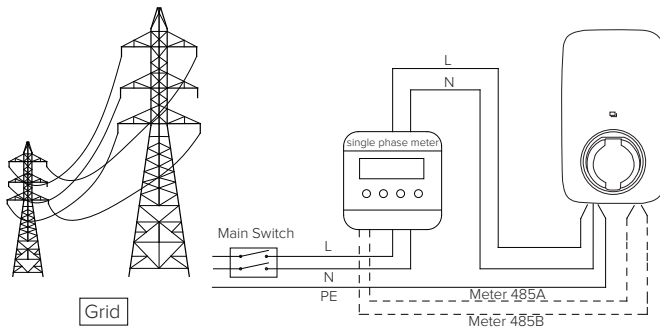

Single phase(7.3kW)

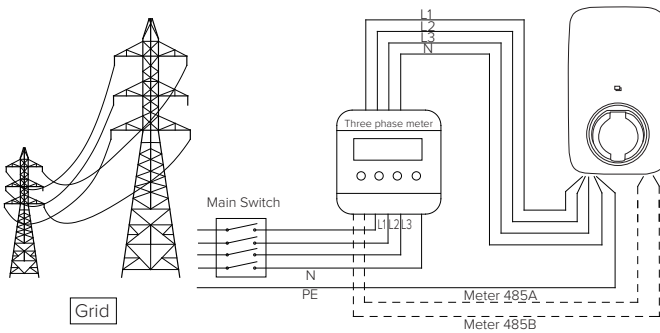

Three phase(11kW&22kW)

Step 1:

Use crimping pliers to crimp the tubular terminal (I) and cable.

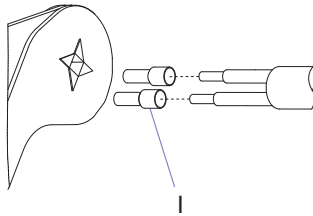

Step 2:

Install the communication cable (wire diameter $\varnothing 3\sim 5\text{mm}$) from the communication port.

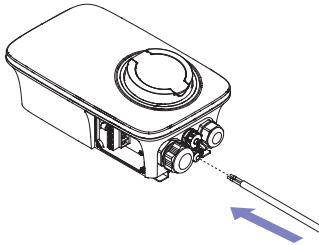

Step 3:

Install the cable into the signal terminal, tighten the screw and compress the tubular terminal.

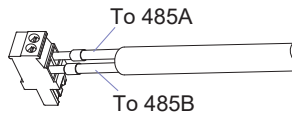

Step 4:

Fix the male and female ends of the signal terminal by connecting them.

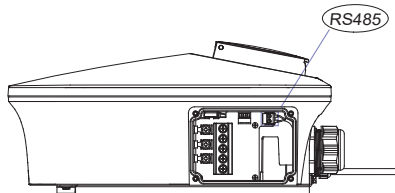

- Load curtailment connections (wiring for the EV charger side)

Trim all cables (wire diameter 0.2mm^2) to 20mm (as shown in the figure), peel off the insulation sheath to expose the conductor by about 8mm.

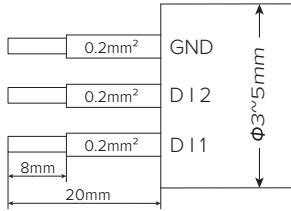

Note

- Please refer to the local regulations on the cable model and color during installation.
- See the third party's instructions on receiver for details of the wiring of the other end.

Step 1:

Use crimping pliers to crimp the tubular terminal (1) and cable.

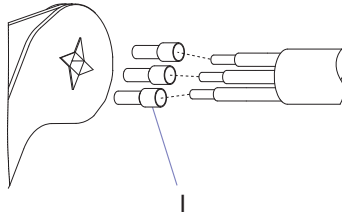

Step 2:

Install the communication cable (wire diameter $\phi 3 \sim 5\text{mm}$) from the communication port.

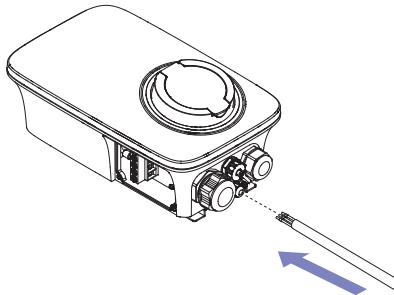

Step 3:

Install the cable into the signal terminal, tighten the screw and compress the tubular terminal.

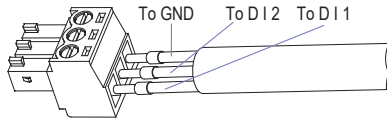

Step 4:

Fix the male and female ends of the signal terminal by connecting them.

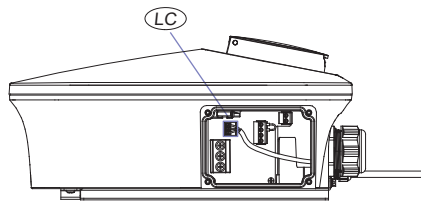

Single phase(7.3kW)

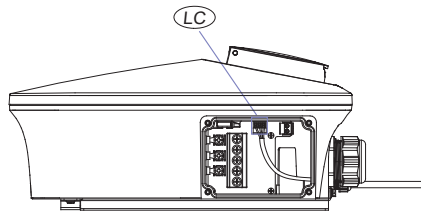

Three phase(11kW&22kW)

- CT sensor connections (Only Single phase 7.3kW)

The CT should be clamped on the main live line of the grid side. The arrow on the CT should be pointing towards the EV charger. If the CT is fitted in the wrong orientation, anti-backflow function will fail.

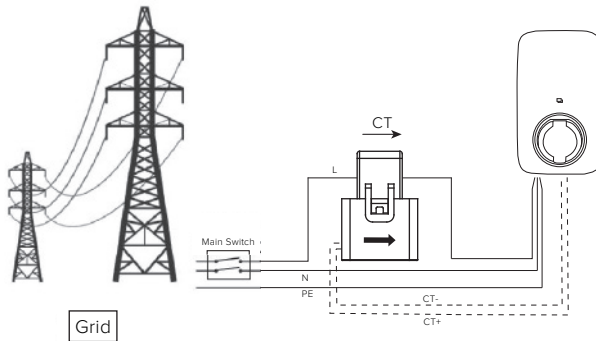

Note

The availability of network connectivity is dependent on the model variant.

Step 1 :

1. Use crimping pliers to crimp the tubular terminal (I) and cable.
2. Take out the CT Sensor.

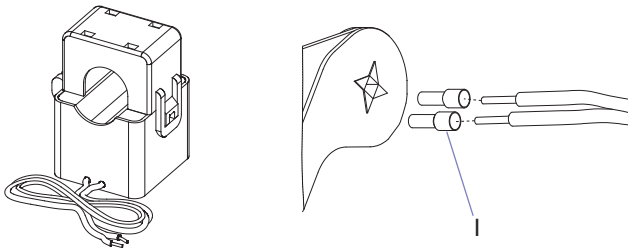

Step 2:

Install the communication cable from the communication port.

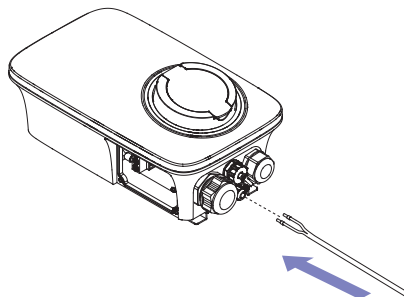

Step 3:

Install the cable into the signal terminal, tighten the screw and compress the tubular terminal.

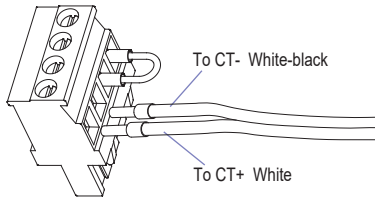
**Step 4:**

Fix the male and female ends of the signal terminal by connecting them.

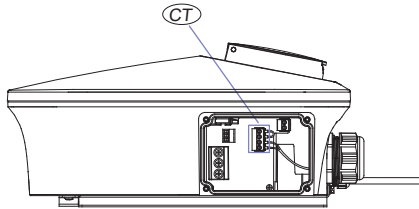
**Step 5:**

Lock the side cover and complete the installation.

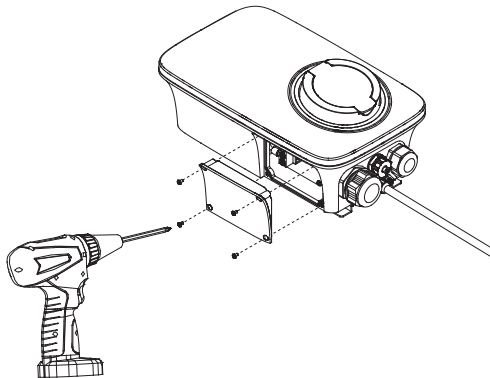

Network connection

- For Ethernet:

The network cable interfaces of the charging pile are as follows:

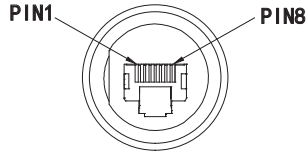

PIN	1	2	3	4	5	6	7	8
Color	White/Orange	Orange	White/Green	Blue	White/Blue	Green	White/Brown	Brown

Note

Please refer to the local regulations on the cable model and color during installation. The availability of network connectivity is dependent on the model variant.

Step 1:

Pass the network cable through connector (L) and connect the network cable to the RJ45 connector.

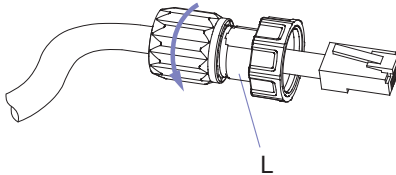

Step 2:

1. Unscrew the dust cover.
2. Insert the RJ45 communication connector on which the network cable is installed into the Ethernet port.

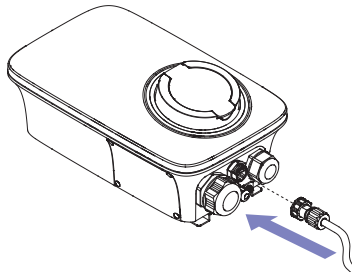

Step 3:
Tighten the connector nut to complete the installation.

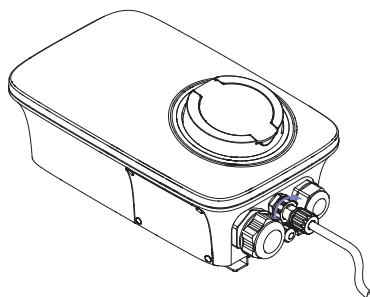

- For 4G:

Note

The availability of network connectivity is dependent on the model variant.

Step 1:

1. Using a flathead screwdriver, push in the tabs connecting the face cover to the charging unit. There are 10 tabs in total, located in the positions marked in the following picture.
2. Open the face cover.

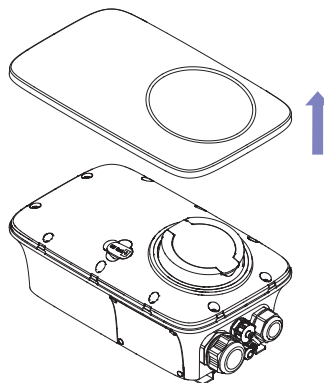
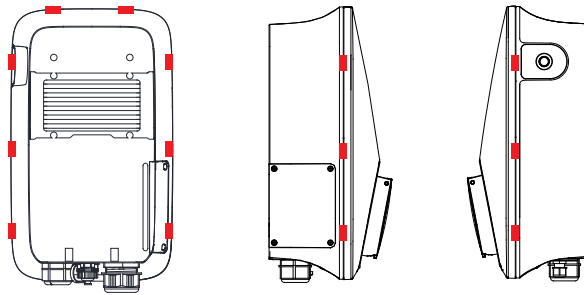

Step 2:

Open the SIM card cover and insert the SIM card (When inserting the SIM Card, please make sure the direction must be the same as the picture shown below).

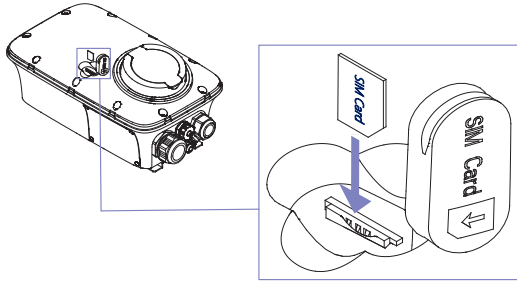
**Step 3:**

Close the SIM card cover, install the face cover, and complete the installation.

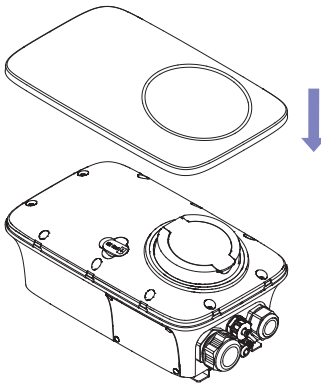

7 Operation

Charging mode and Operation

There are three charging modes which can be set on the corresponding interface of the APP: plug and charge, controlled, locked .

A. Plug and Charge mode

Charging will start automatically after EV plugged in. If you want to stop the charging, just press the stop button on the side of the charger.

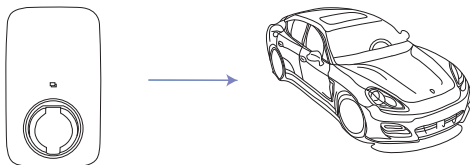

- Start Charging:

1. Set the charger to the plug and charge mode
2. Insert the charging plug into the EV.
3. Charging session started.

- Stop Charging:

Press the stop button on the side of the charger.

B. Controlled mode

Initiate or cease charging on the APP or by swiping RFID card on this mode. You can also use APP for Reservations.

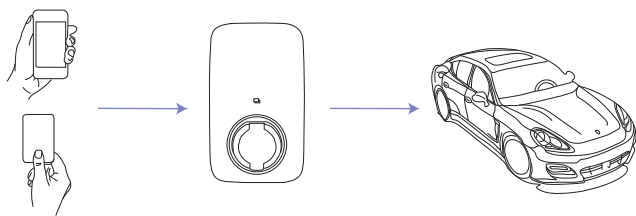

Controlled mode with RFID card

▪ Start Charging:

1. Set the charger to the controlled mode.
2. Insert the charging plug into the EV.
3. Swipe card.
4. Charging session started.

▪ Stop Charging:

1. Swipe card.
2. Charging session end.

Controlled mode with APP

▪ Start Charging:

1. Set the charger to the controlled mode.
2. Insert the charging plug into the EV.
3. Click to start the charge on the APP.
4. Charging session started.

▪ Stop Charging:

1. Click to stop the charge on the APP.
2. Charging session end.

C. Locked mode

On this mode, the charger is locked and can not work.

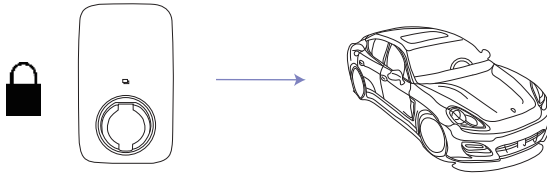

8 Maintenance

If fault occurs, users can check the fault information on the APP.

No.	Fault code on app	Solution
1	Electronic lock fault	Set the electronic lock status to the correct position. Or seek help from the installers/distributors.
2	Emergency stop fault	Reset the emergency stop button. Or seek help from the installers/distributors.
3	Abnormal CP voltage	Seek help from the installers/distributors.
4	Abnormal AC output contactor	Seek help from the installers/distributors.
5	Over current	Seek help from the installers/distributors.
6	Over voltage	Wait for the grid voltage to return to normal. Or seek help from the installers/distributors.
7	Under voltage	Wait for the grid voltage to return to normal. Or seek help from the installers/distributors.
8	Electric leakage	Seek help from the installers/distributors.
9	Reverse connection of lin N	Seek help from the installers/distributors.
10	Abnormal frequency	Wait for the grid frequency to return to normal. Or seek help from the installers/distributors.
11	Over temperature of charging interface	Wait for the temperature of charging interface to return to normal. Or seek help from the installers/distributors.

9 Decommissioning

9.1 Dismantling the charger

- Disconnect the charger from AC input and AC output.
- Disconnect communication and optional connection wirings. Remove the charger from the bracket.
- Remove the bracket if necessary.

9.2 Packaging

If possible, please pack the charger with the original packaging. If it is no longer available, you can also use an equivalent box that meets the following requirements.

- Suitable for loads more than 30 kg.
- Contains a handle.
- Can be fully closed.

9.3 Storage and Transportation

Store the charger in dry place where ambient temperatures are always between -40°C - $+70^{\circ}\text{C}$. Take care of the charger during the storage and transportation; keep less than 4 cartons in one stack. When the charger or other related components need to be disposed of, please ensure it is carried out according to local waste handling regulations. Please be sure to deliver any charger that needs to be disposed from sites that are appropriate for the disposal in accordance with local regulations.



If you need more information, please follow us on YouTube.
scan the QR code or visit
<https://www.youtube.com/@foxess5669>

Fox ESS declares that the radio equipment type AXXXXXl.E.B and AXXXXX-T2s.B are in compliance with Directive 20 14/53/EU. The full text of the EU declaration of conformity is available at the following internet address: WWW.FOX.ESS.COM
Address: FOXESS CO., LTD. No. 939, jinhai 3rd Road, Longwan District, Wenzhou, Zhejiang, China
Tel: +86(510)68092998(General)+86(510)68101679(Sales)
Website: www.fox-ess.com